



Polaris 280 TankTrax Conversion Kit Installation

Kit Contains:

- Top Housing
- Bottom Housing
- TankTrax® Tire
- Axle Block (2)
- Idler Wheel with Ball Bearings
- Wheel Washer, Idler Wheel
- Wheel Screw, Idler Wheel
- Swing Axle Tee
- Swing Axle
- Swing Axle Tee Screw
- Tap Screw

1. Remove the feed hose, head float, sweep hose, adjustment screw, double-wheel side tires, and the top and bottom housing. Store or discard the tires and the housings.

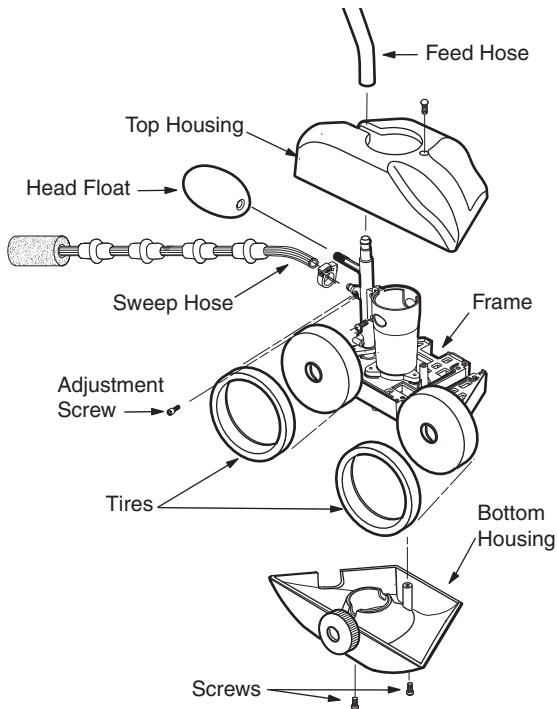

2. Push the axle tee screw through the large hole in the new bottom housing. Mount the swing axle using swing axle tee. Install tap screw to secure swing axle.

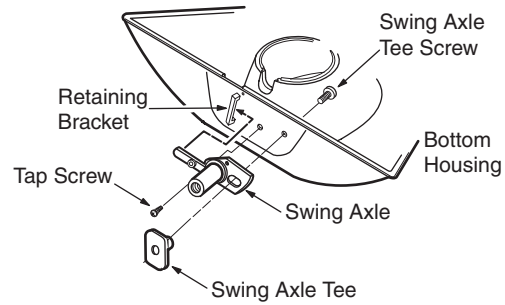

3. Secure the idler wheel to the swing axle using the wheel washer and plastic wheel screw. **Do not over tighten.** The wheel should spin freely.

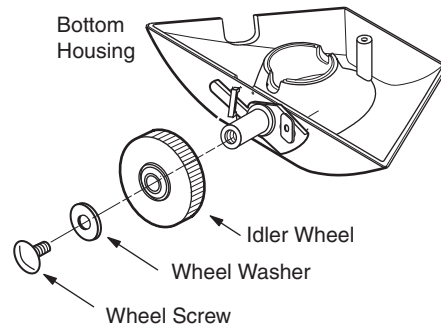

4. Loosen and remove both the front and back double-wheel side wheel screws, wheel washers and wheels. Remove and store or discard both double-wheel side axles. Install the new axle blocks leaving the back wheel axle screws loose for further adjustment.

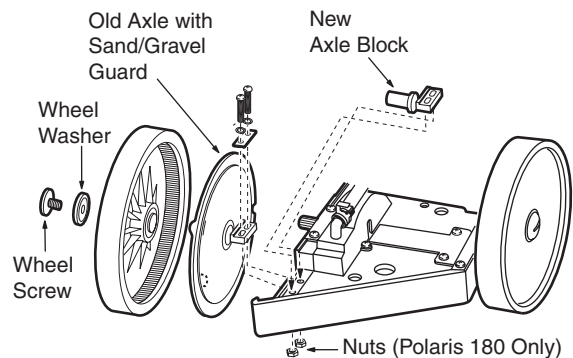

- Reinstall the back wheel.
- Attach the new bottom housing with the idler wheel to the frame.

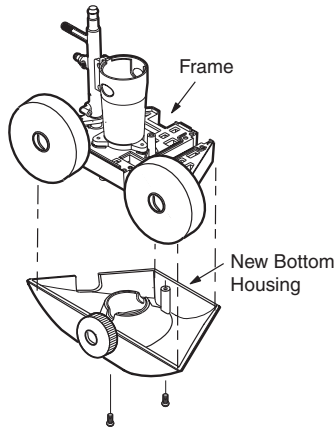

- Slide the TankTrax tire onto the wheels. Verify that the idler wheel is seated inside the tire.

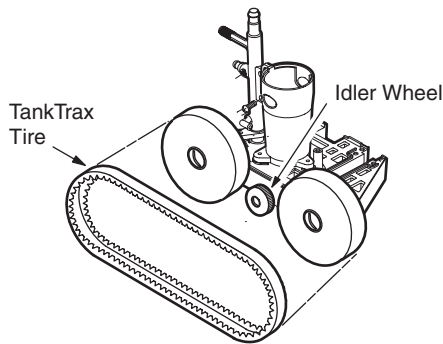

- Use a ruler to measure the distance from the ground line to the inside lip of the upper track. Slide the rear double-side wheel back until proper tension is achieved at 6-3/4". Tighten axle block screws.

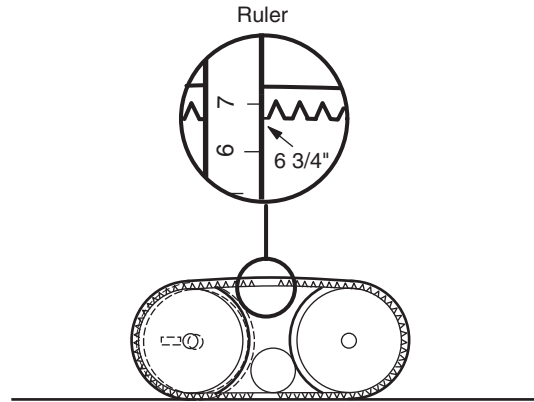

- Install the new top housing. Reinstall the adjustment screw, sweep hose, head float, feed hose and bag.

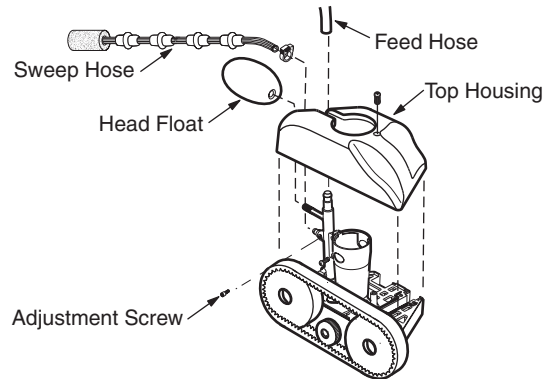

Before returning the Polaris to regular cleaning:

- Check for proper pressure (28 to 32 psi).
- Confirm proper wheel speed (28 to 32 rpm).