



# Jandy Pro Series FloPro™ (FHP) Pump Body, Tailpiece Assembly, Tailpiece O-ring, and Base, Replacement Kit Instructions

## ⚠ WARNING

**FOR YOUR SAFETY:** This product must be installed and serviced by a contractor who is licensed and qualified in pool equipment by the jurisdiction in which the product will be installed where such state or local requirements exist. The maintainer must be a professional with sufficient experience in pool equipment installation and maintenance so that all of the instructions in this manual can be followed exactly. Before installing this product, read and follow all warning notices and instructions that accompany this product. Failure to follow warning notices and instructions may result in property damage, personal injury, or death. Improper installation and/or operation will void the warranty.

These instructions are to be used with the following Jandy Replacement Parts:

**R0479800--FHP Pump Body Replacement Kit**

**R0327301--FHP Tailpiece, O-ring, and Union Nut Replacement Kit**

**R0337601--FHP Tailpiece O-ring Replacement Kit**

**R0486700--FHP Pump Base Replacement Kit**

## ⚠ WARNING

Before servicing the pump, be sure to switch off the circuit breaker to the circuit supplying power to the pump. Failure to do so could result in property damage, severe personal injury, and/or death.

## 1. Introduction

This document provides instructions for the proper replacement of the pump body, backplate o-ring, tailpiece, tailpiece o-rings, tailpiece union nuts, and pump base on the Jandy Pro Series FloPro (FHP) Series Pump.

Refer to Figure 1 and the parts list on page 4 to identify the parts in the replacement kits. (The parts in bold type are in the replacement kits.)

These instructions must be followed exactly. Read them completely before starting any of the procedures.

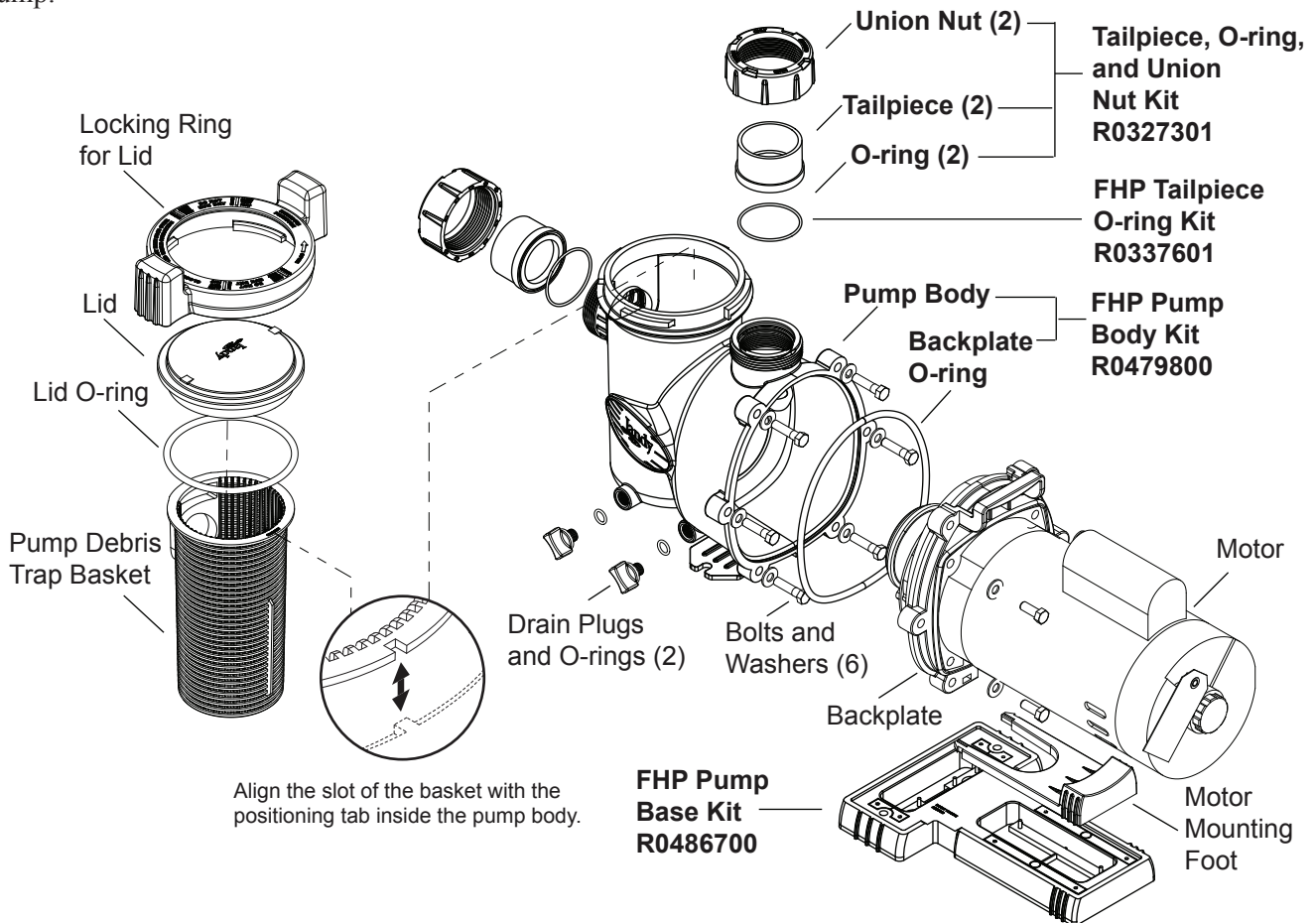

Figure 1. FHP Exploded View

## 2. Pump Disassembly

### WARNING

Due to the potential risk of fire, electric shock, or injuries to persons, Jandy Pro Series Pumps must be installed in accordance with the National Electrical Code® (NEC®), all local electrical and safety codes, and the Occupational Safety and Health Act (OSHA). Copies of the NEC may be ordered from the National Fire Protection Association, 470 Atlantic Ave., Boston, MA 02210, or obtained from your local government inspection agency.

In Canada, Jandy Pro Series Pumps must be installed in accordance with the Canadian Electrical Code (CEC®).

1. Turn off the pump. Switch off the circuit breaker to the pump motor. Close all necessary valves to prevent pool water from reaching the pump.
2. Remove the drain plugs and o-rings to drain the water from the pump. See Figure 1.
3. Using a 9/16" wrench, loosen the six (6) bolts connecting the pump body to the motor backplate.
4. Pull the motor with attached backplate assembly out of the pump body. Remove the backplate o-ring from the pump body, as shown in Figure 1.
5. Unsnap the mounting foot and pull it straight out from the pump body assembly.
6. Remove the tailpiece, union nuts and o-rings from the inlet and outlet ports of the pump body. Use a spanner wrench to help loosen the union nuts.
7. Turn the pump lid's locking ring counter-clockwise until 'START' aligns with the ports. Remove the locking ring, lid and lid o-ring.
8. Lift the pump debris trap basket out of the pump.
9. Remove the nuts and washers anchoring the pump to the equipment pad and remove the pump body.

## 3. Pump Body Replacement

Refer to Figure 2 and the associated parts list to identify the parts included in the replacement kit.

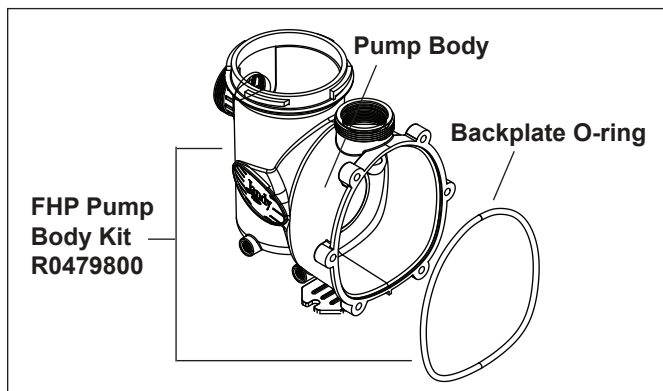

Figure 2. FHP Pump Body Kit

FHP Pump Body Replacement Kit Parts List	
Description	R0479800
Pump Body	1
O-ring, Backplate, FHP	1
Instructions	1

1. Place the new pump body into the correct position on the equipment pad and anchor it to the pad with the nuts and washers removed during disassembly.
2. To prevent air from leaking into the system, remove any debris around the o-ring and mating surfaces. Make sure the o-ring and mating parts are clean.

### WARNING

Trapped air in the system can cause the filter lid to be blown off, which can result in death, serious personal injury, and/or property damage. Be sure all air is out of the system before operating.

3. Reinstall the drain plugs with o-rings onto the pump body. **Hand-tighten only.** Do not exceed 8-10 in-lbs of torque.
4. Reinstall the o-rings into the groove of the tailpieces and hand-tighten the union nuts into the ports of the pump. **Do not use any tools to tighten the union nuts.**
5. Attach the motor mounting foot to the pump body assembly by snapping the mounting foot on the pump body assembly.
6. Slide the motor and backplate assembly into the pump body.
7. Slide the diffuser into the inside centric hole of the pump body. While supporting the motor, start two (2) screws on opposite sides. Then start the other four (4) screws.
8. Tighten the screws lightly in a crossing "X" pattern using a 9/16" wrench. Start with the inner (middle) two (2) screws, then tighten the outer (top and bottom) four (4) screws to draw the backplate to the body in an even manner. When all the screws are snug, tighten in the same order to 10 ft-lbs of torque.
9. Place the pump debris trap basket assembly into the pump body. Make sure that the slot of the basket is aligned with the positioning tab inside the pump body. See Figure 1.

**⚠ CAUTION**

A misaligned basket will cause the lid to be improperly seated, allowing an air leak, which could result in pump damage.

10. Fill the pump trap with water before starting the pump.
11. To prevent air from leaking into the system, remove any debris around the o-ring seat.

**⚠ WARNING**

Trapped air in the system can cause the filter lid to be blown off, which can result in death, serious personal injury, and/or property damage. Be sure all air is out of the system before operating.

12. Place the lid with locking lid onto the pump body, and align 'START' with the ports. Then turn the lid's locking ring clockwise until 'LOCKED' aligns with the ports. **Hand-tighten the lid. Do not use any tools.**
13. Return the valves to the proper position for normal operation. Open the filter pressure release valve and bleed the air from the system.
14. When all the air has been bled from the filter, close the pressure release valve.
15. Switch on the circuit breaker to the pump motor.
16. Turn on the power to the pump and check for normal operation.

**4. Tailpiece, O-ring, and Union Nut Replacement**

Refer to Figure 3 and the associated parts list to identify the parts included in the replacement kits.

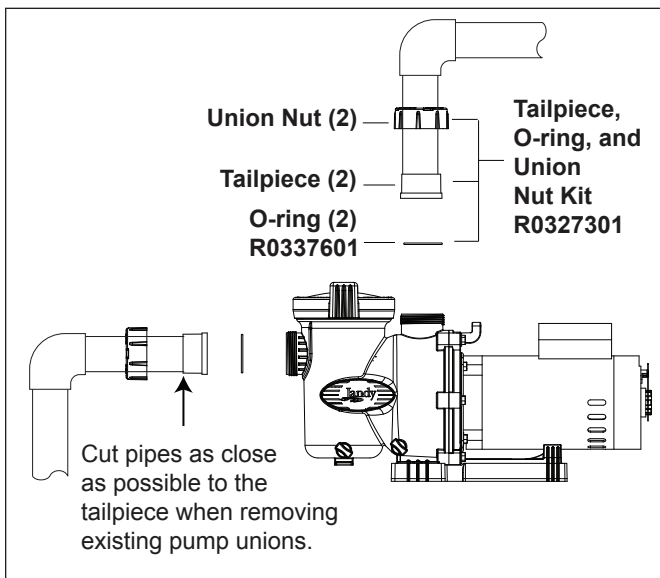

**Figure 3. Tailpiece, O-ring, and Coupling Nut Kit**

**Tailpiece, O-ring and Union Nut Replacement Kit Parts List**

Description	R0327301	R0337601
	2" x 2" Tailpiece	2
Union Nut	2	--
Tailpiece O-ring	2	2
Instructions	1	1

**4.1 Removal of Tailpiece**

1. Comply with the warning and follow Steps 1-2 in Section 2, Pump Disassembly.
2. Loosen the union nuts on the inlet and outlet ports and pull them away from the pump body, as shown in Figure 3. If necessary, use a spanner wrench to help loosen the union nuts.
3. Remove the tailpiece o-rings.

**NOTE** If you are **only** replacing the tailpiece o-rings (Kit R0337600), go directly to Section 4.3.

4. Remove the tailpieces from the pipes:
  - a. Cut the inlet and outlet pipes as close as possible to the existing tailpieces, as shown in Figure 3.
  - b. Discard the tailpieces and union nuts removed from the plumbing.

**NOTE** These kits do not include couplers or fittings that may be needed for replumbing.

**4.2 Replacement of Tailpiece**

1. Slip the new union nut onto the pipes with the open threaded end of the nut facing the pump.
2. Prepare the end of the pipe with the proper PVC/CPVC primer and glue. Make sure to follow the primer and glue manufacturer's instructions for the preparation procedures and curing times.
3. Attach the slip fit side of the tailpiece to the end of the 2" pipe. (See Figure 4.) Allow the glue to cure completely and then continue with Section 4.3.

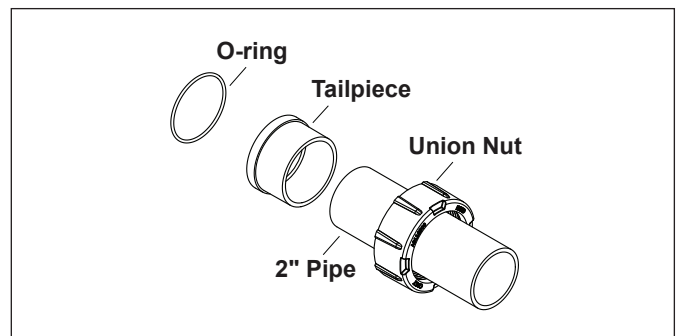

**Figure 4. Tailpiece Assembly**

### 4.3 Replacement of Tailpiece O-rings

- To prevent air from leaking into the system, remove any debris around the o-rings and mating surfaces. Keep the o-rings and mating parts clean.

#### **⚠ WARNING**

Trapped air in the system can cause the filter lid to be blown off, which can result in death, serious personal injury, and/or property damage. Be sure all air is out of the system before operating.

- Place the new o-rings into the grooves of the tailpieces. Hand-tighten the union nuts into the ports. **Do not use tools to tighten the union nuts.**
- Complete assembly by following Steps 13-16 in Section 3, Pump Body Replacement.

### 5. Pump Base Replacement

Refer to Figure 5 and the associated parts list to identify the part in the replacement kit.

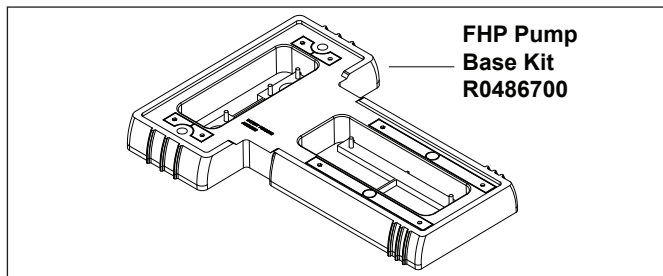

Figure 5. Pump Base Kit

FHP Pump Base Replacement Kit Parts List	
Description	R0486700
Pump Base	1
Instructions	1

- Comply with the warning and follow Step 1 in Section 2, Pump Disassembly.
- Remove the two (2) bolts that attach the base and housing pump to the foundation.
- Replace the base and attach it and the pump housing to the foundation.
- If you need to raise the pump higher:
  - Cut the plastic bars connecting the top and bottom sets of spacers, as shown in Figure 6.

- Snap the two (2) top spacers and two (2) bottom spacers off the base.
- Align the pins in the four (4) spacers with the holes in the base and snap the spacers into place, as shown in Figure 7.
- Attach the base assembly and pump housing to the foundation.

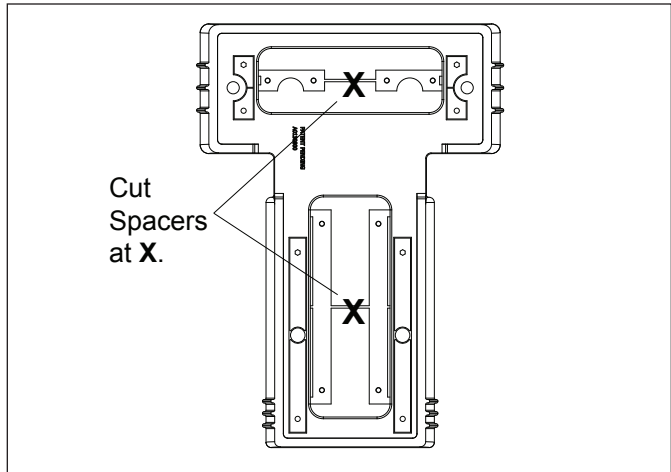

Figure 6. Cut Spacers

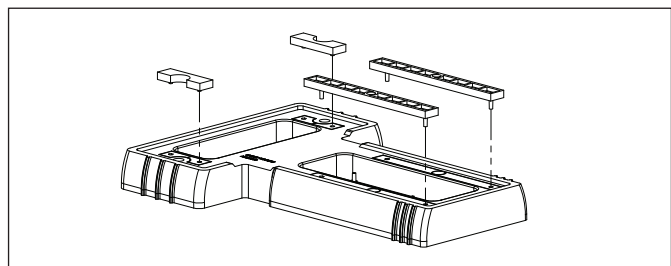

Figure 7. Place Spacers in Base

- Switch on circuit breaker to pump motor. Turn on pump and check the system for normal operation.

### 6. Parts List

Description	R0479800	R0327301	R0337601	R0486700
Body Pump	1	--	--	--
O-ring, Backplate, FHP	1	--	--	--
Tailpiece, FHP	--	2	--	--
Tailpiece O-ring, FHP	--	2	2	--
Tailpiece Union Nut, FHP	--	2	--	--
Pump Base, FHP	--	--	--	1
Instructions	1	1	1	1

Zodiac Pool Systems, Inc.  
2620 Commerce Way, Vista, CA 92081  
1.800.822.7933 | www.ZodiacPoolSystems.com

©2015 Zodiac Pool Systems, Inc. ZODIAC® is a registered trademark of Zodiac International, S.A.S.U., used under license. All trademarks referenced herein are the property of their respective owners.