

Jandy® Leaf-B-Gone™ Pressure Test Kit Instructions

Pressure test the floor canister for leaks after all joints are cured.

The Jandy Leaf-B-Gone floor canister for concrete pools is plugged at the factory, ready for pressure testing, and sealed with a protective cover. Do not remove the cover until the final finish is applied.

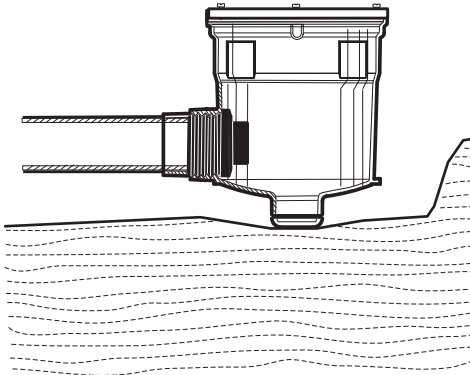

Cutaway of Jandy Leaf-B-Gone Floor Canister for Concrete Pools

To test the floor canister line:

1. Apply Rector Seal 5 to the threads of the deck canister inlet fitting and the male adapter.
2. Install adapter in fitting and hand tighten. Use channel locks on the smaller part of the adapter to tighten 2 to 3 turns.

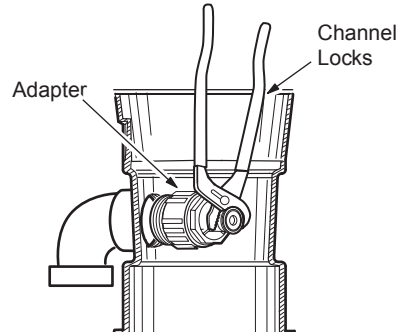

Cutaway of Deck Canister

3. Install the pressure test assembly onto the adapter fitting. Test plumbing line to 35 PSI or according to local codes.

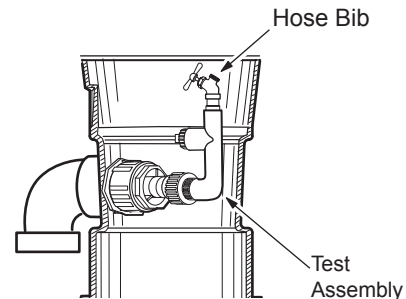

Cutaway of Deck Canister

