



# REVOLUTION™

## 6-PORT VALVE

Jandy In-Floor Cleaning Systems

---

### Installation and Maintenance Guide

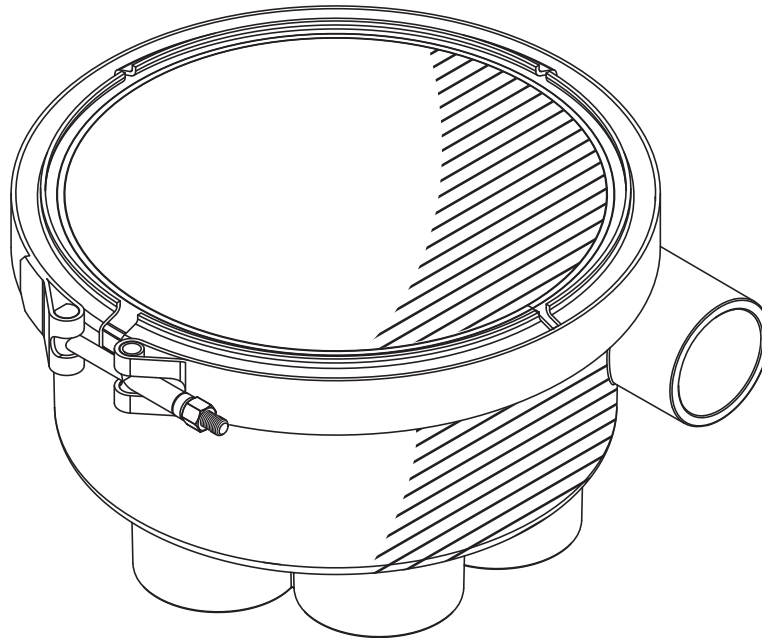

#### **⚠ WARNING**

**FOR YOUR SAFETY - This product must be installed and serviced by a contractor who is licensed and qualified in pool equipment by the jurisdiction in which the product will be installed where such state or local requirements exist. In the event no such state or local requirement exists, the installer or maintainer must be a professional with sufficient experience in pool equipment installation and maintenance so that all of the instructions in this manual can be followed exactly. Before installing this product, read and follow all warning notices and instructions that accompany this product. Failure to follow warning notices and instructions may result in property damage, personal injury, or death. Improper installation and/or operation may void the warranty.**

#### **Cover-Pools Incorporated**

2580 S Decker Lake Blvd, STE 300 West Valley City, UT 84119

855.280.6465 toll-free | 801.906.6701 fax

[jandyinfloor.custsupport@fluidra.com](mailto:jandyinfloor.custsupport@fluidra.com)

[Jandy.com/in-floor](http://Jandy.com/in-floor)

T0073500 Rel-0005

# Table of Contents

<b>Important Safety Information .....</b>	<b>3</b>
<b>Jandy In-Floor Design Services .....</b>	<b>4</b>
<b>For Customer Service or Support.....</b>	<b>4</b>
<b>Introduction.....</b>	<b>5</b>
<b>Components.....</b>	<b>5</b>
<b>Installation.....</b>	<b>6</b>
<b>1. Site Planning.....</b>	<b>6</b>
<b>2. Plumbing the System .....</b>	<b>6</b>
Feed Lines for Cleaning Heads .....	6
Cleaning Head Risers .....	7
Auxiliary Equipment .....	7
6-Port Valve Discharge Lines.....	8
Plumbing For Cold Climates .....	8
Pressure Testing .....	9
<b>3. Preparing the System.....</b>	<b>9</b>
Cut Stub-ups .....	9
Install Collars .....	10
Install Valve Cassette Assembly .....	11
<b>4. Starting the System.....</b>	<b>11</b>
<b>5. Install the Cleaning Heads.....</b>	<b>11</b>
<b>Operation and Routine Maintenance .....</b>	<b>12</b>
Cleaning the Filtration System .....	12
Changing Cleaning Heads.....	12
Winterizing .....	12
<b>Troubleshooting .....</b>	<b>13</b>

# Important Safety Information

## READ AND FOLLOW ALL INSTRUCTIONS.

### **WARNING**

Read these instructions completely before starting the procedures. If these instructions are not followed exactly, a fire or electric shock could result, causing property damage, personal injury, and/or death.

### **WARNING**

This product must be installed and serviced by authorized personnel, qualified in pool/spa installation. Improper installation and/or operation can create an unwanted electrical hazard which can cause serious injury, property damage, or death. Improper installation and/or operation may void the warranty.

### **WARNING**

Installation of this equipment should be performed by a licensed pool contractor and conform to the National Electrical Code® (NEC)®, or Canadian Electrical Code (CEC) in Canada. All applicable local installation codes and regulations must be followed.

### **WARNING**

This manual contains important information about the installation, operation, and safe use of this product. This information should be given to the owner/operator of this equipment.

### **WARNING**

#### **To reduce the risk of electrical shock:**

- Install all electrical equipment at least 5 feet (1.5 m) from inside wall of pool or spa.
- Disconnect power before servicing this equipment.

### **WARNING**

To reduce the risk of injury, do not allow children to handle this equipment unless they are closely supervised.

**To ensure complete cleaning and to qualify for the 99% cleaning guarantee**, the pool builder must fax or email a Design Fact Sheet along with a scaled pool plan for FREE In-Floor Design Service prior to plumbing the pool.

Email: [jandyinfloor.design@fluidra.com](mailto:jandyinfloor.design@fluidra.com)

Fax: (801)-906-6701

**If the pool design or dimensions change during excavation, a new design plan must be drawn, or the cleaning guarantee may be void.**

Install the valve above ground and the finished pool water level. **Do not bury valve after installation.**

Install cleaning heads and nozzles according to the Design Plan.

If pool includes an elevated spa, install a check valve on the line feeding the spa heads to avoid spa draining. Install other check valves (as normal) to avoid spa return jets and suction lines from draining.

**SAVE THESE INSTRUCTIONS.**

## For Customer Service or Support

**To contact Jandy In-Floor:** Customer Service  
2580 S Decker Lake Blvd, STE 300  
West Valley City, UT 84119  
  
toll-free: 855.280.6465  
email: [jandyinfloor.custsupport@fluidra.com](mailto:jandyinfloor.custsupport@fluidra.com)  
  
[Jandy.com/in-floor](http://Jandy.com/in-floor)

# Introduction

The 6-Port Revolution valve is a hydraulically-driven, in-floor pool cleaning system from Jandy®. The 6-port valve provides dependable and efficient in-floor cleaning by maximizing water flow through strategically placed cleaning heads to give your pool a robust and thorough cleaning.

Installation of this equipment should be performed by a licensed pool contractor and should comply with all applicable local laws, ordinances, codes, and regulations. Failure to follow recommended installation methods and maintenance procedures could cause damage to pool equipment and/or personal injury, and may void the warranty.

## Components

### WK000030–Revolution™ 6-Port Valve

(Gauge Assembly sold separately)

### WK000036–Pre-plumb kit

(Cassette Assembly sold separately)

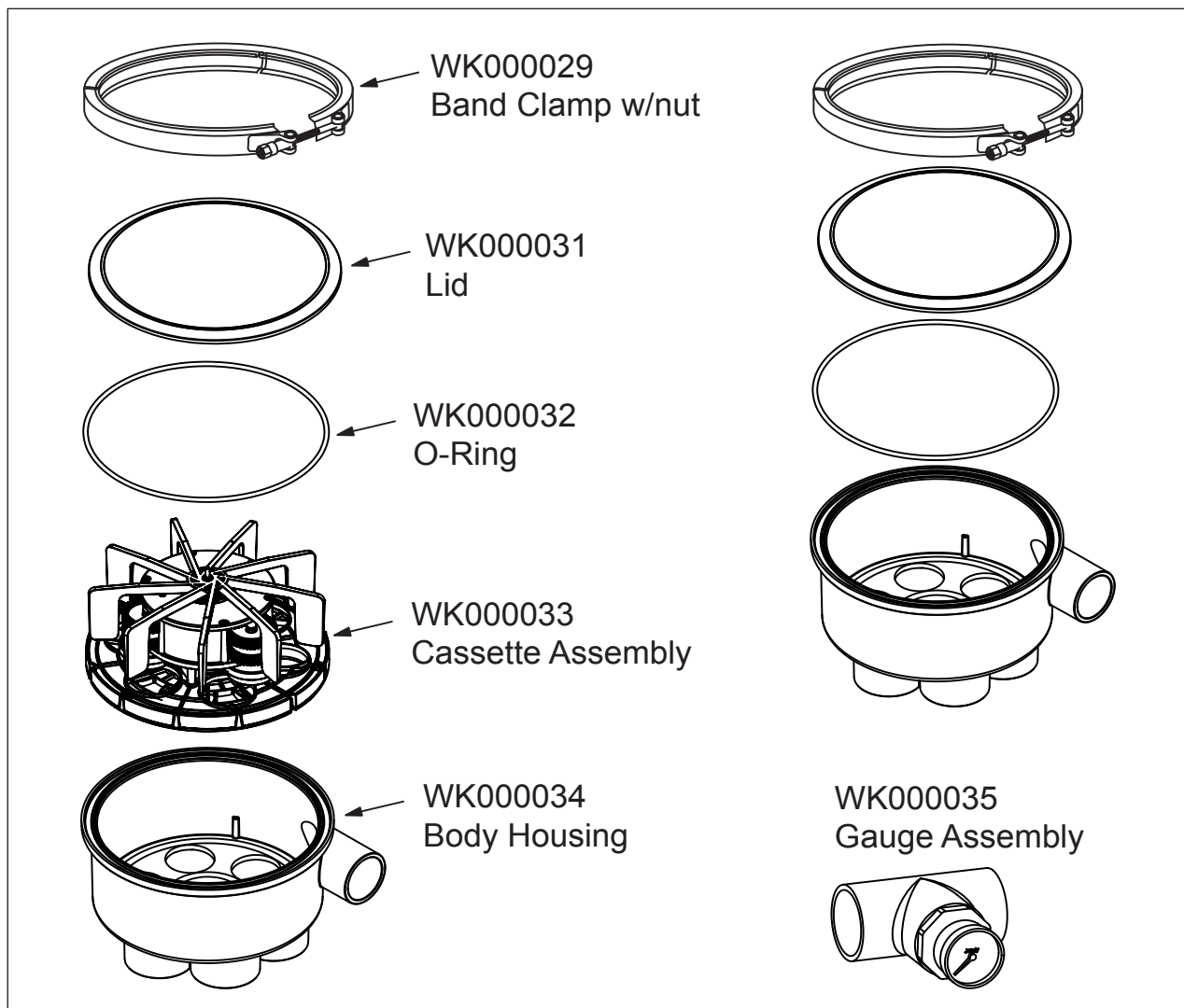

# Installation

## 1

### Site Planning

Verify that the excavated pool matches the Jandy In-Floor certified pool plan. Check the break, width, depth, and designated step/bench locations. Jandy In-Floor design dimensions are from **finished** pool, not excavation. **If any dimensions have changed, a new plan must be drawn to ensure cleaning and warranty.**

Position the valve as close as possible to the swimming pool or water feature to reduce piping and improve performance. The valve can be placed near the other pool equipment for aesthetic purposes. However, the installer must follow the pipe size guidelines found on the certified pool plan which includes a minimum requirement of 2" PVC SCH40 for all floor inlets.

Install the valve so that the body housing and outlet ports are above ground and the finished pool water level. If the valve must be installed below water level, check valves or manual valves on the inlet and outlet ports are required to prevent flooding of the valve.

Lay out system so feed pipes enter the pool in the center of the wall closest to the pool equipment and valve. Use a check valve on the feed line in elevated spas to prevent spa water from flowing back into the pool.

**Follow the certified design plan to position and stake the cleaning head locations.** Each head has a designated nozzle that has a precise cleaning radius (see Figure 1). Perimeter heads have a 1 ft. (0.3 m) overlap. Mark the cleaning radius around each stake to verify cleaning coverage (Figure 2).

Flare steps and benches to ensure debris does not get cornered (see Figure 2). Heads should be positioned 2 in. (5.1 cm) from the outer edge on steps and benches.

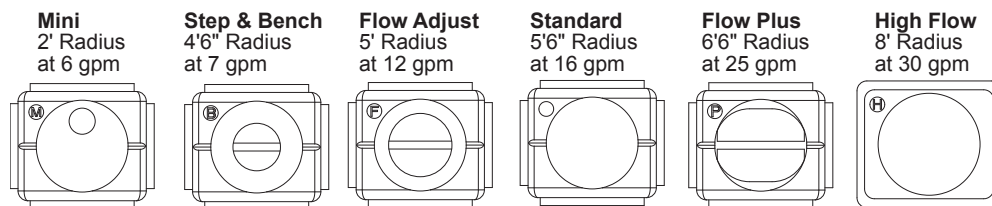

Figure 1. Nozzle options

## 2

### Plumbing the System

#### Feed Lines for Cleaning Heads

The Jandy In-Floor certified pool plan indicates which cleaning heads will be plumbed together to form a bank. Run all feed lines to the top of the bond beam to facilitate easy valve hookup. Number the lines according to the design plan (see Figure 2).

- Excavate a niche in pool wall, 6" x 24" (15.2 cm x 61.0 cm) down to the pool floor.
- Make line trench depth sufficient to cover all pipes with 6" (15 cm) of soil.
- Do not cross lines in floor.
- Use 2" (5.1 cm) Schedule 40 PVC pipe.
- Use 45° and sweep elbows to improve water flow.
- Use 90° elbows or tees at each head location.
- Left justify heads next to sharp corners.

#### For Vinyl Liner Pools:

- Stake but do not plumb lines until walls are set; plumbing lines are fed under walls.
- Vinyl collars are not adjustable, stub-ups **must be** perpendicular to finished pool floor.
- Dig trenches 8 in. (20.3 cm) below excavation grade to accommodate setting of fittings.

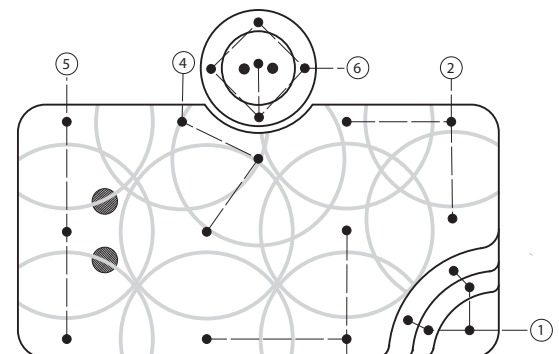

Verify min. 1' overlap Radius  
Figure 2. Plumbing Design Plan

## Cleaning Head Risers

Risers or stub-ups are glued into 2" (5.1 cm) Tee's, 90-degree elbows, to stub-ups through the pool shell.

Match the riser width to collar width.

- 2" collars require 2" class 200 pipe (no reaming required) or 2" schedule 40 pipe (reaming required)
- 2.5" collars require 2.5" (6.35 cm) Schedule 40 Pipe (no reaming required)
- Position stub-up perpendicular (90°) to the slope of the finished pool floor and secured to avoid movement during gunite process. (see Figure 3)
- Top of stub-ups must be 6" (15.2 cm) above finished elevation.
- During gunite application, leave a 1" (2.5 cm) deep x 1" (2.5 cm) wide well around each stub-up.

**Note:** If 2" schedule 40 stub-ups are used, pipe reamer (part # 4-17-2) is required to allow the 2" collar to fit into the pipe.

**Hint:** Save plumbing time by using 2.5" (Part # 5-9-150) or 2" (Part #WK000001) Prefabricated stub ups. They glue directly into 2" schedule 40 fittings, don't require reaming and are ready for pressure testing.

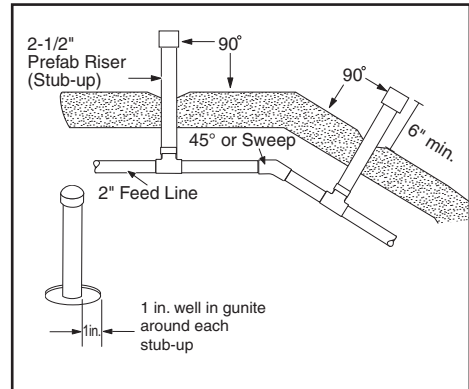

Figure 3. Cleaning Head Risers

## Auxiliary Equipment

**Pump:** Choose an appropriate pump size and style to meet the GPM flow rate minimums specified on your certified pool plan. For variable speed pumps, see page 12.

**Heaters:** To compensate for heater system pressure drops, plumb heaters in a bypass line before the water valve, even if the heater has an internal bypass. Perform a temperature rise test to determine where to set the bypass valve (see Figure 7). Ensure proper water flow can be reached.

**Chlorinators:** In-floor systems can be used with erosion feeders, ozone generators, and in-line salt-chlorine generators. Consult manufacturers' instructions for proper installation to protect the water valve and other pool equipment from high concentrations of chlorine or chlorine gas.

**Automatic Pool Cleaners:** When using an automatic pool cleaner with the in-floor system, plumb the dedicated cleaner line (booster pump if applicable) before the valve (see Figure 4).

**Water Features, Falls and Returns:** Plumb so the 6-port valve receives the GPM's mentioned in the certified design during the cleaning sessions.

**Filters:** Use of a filter is required to maintain warranty. Size the filter to exceed the flow requirements of the certified design. Consult manufacturers' installation instructions.

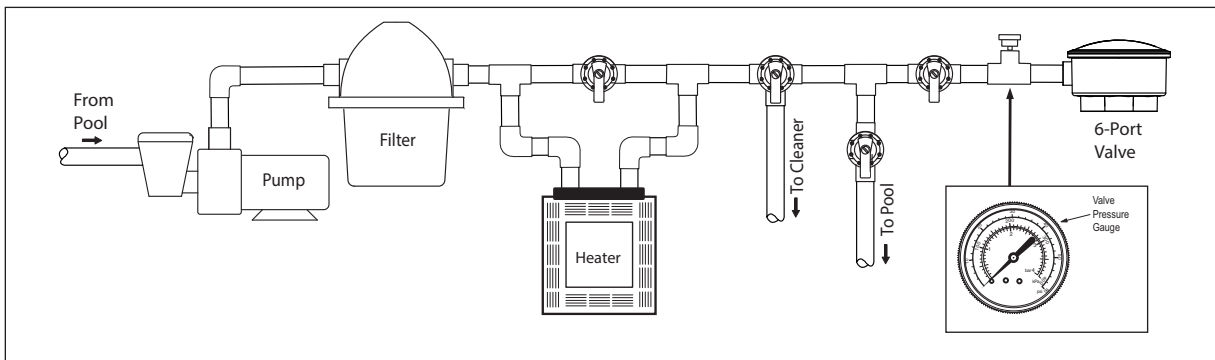

Figure 4. Example of a Plumbing Setup

## 6-Port Valve Discharge Lines

The distribution system is designed to rotate from the shallow end to the deep end; pushing debris to the drain. Port 1 should always be the step or bench port, followed by the shallow bank, etc. Looking down on the valve, it rotates clockwise. If a spa is included, it will require a dedicated line from the valve. Follow the design plan to install the lines in the correct order (See Figure 5).

- Open the valve and remove cassette assembly and packaging prior to gluing. Body housing must be primed heavily before gluing.
- Use heavy bodied PVC glue to connect the PVC pipe to the valve housing using glue manufacturer's instructions. **CAUTION: Do not get glue inside the housing as it will prevent the valve from rotating and void the warranty.**
- Use a 3 in. (7.6 cm) stagger when cutting pipes to provide enough clearance for the elbows.
- Install the discharge lines from the valve in a stacked or flat configuration. **CAUTION: Ensure pipes do not touch each other.**
- Install all lines with a minimum of 6" (15.2 cm) cover or in accordance with local codes.
- If all outlet ports on the valve are not needed, **double-port** the line by tying the unused port into an active port. Customarily, **double-port** lines to the hardest-to-clean area. Refer to the design plan for the proper connections. **CAUTION: Always plumb a check valve in each double-ported line.**
- If a port is used as a return line, install an eyeball fitting at the pool wall to create back pressure on the line. If the wall return line can also receive water pressure from the pump, install a check valve between the Jandy In-Floor valve and wall returns to prevent water from back flowing into the valve.

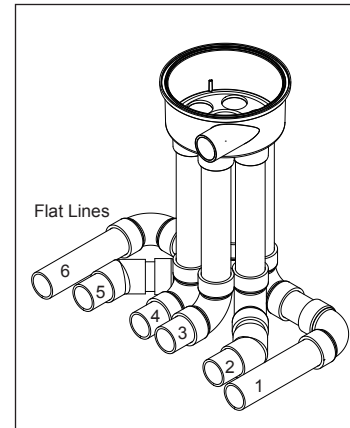

Figure 5. Flat Configuration of Valve Discharge Lines

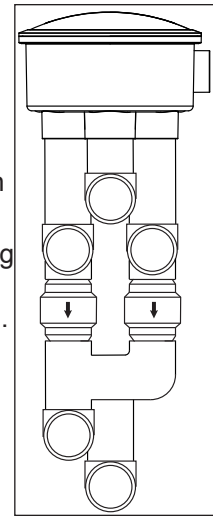

Figure 6. Double-Ported Stacked Lines

## Plumbing For Cold Climates

Prepare for cold weather by plumbing the valve so it can be winterized easily.

- Plumb 2-way valves into each discharge line so they can be pressurized to push water below the freeze zone and sealed to prevent water from coming back up into the valve. (See Figure 7)
- Discharge pipes should extend 24" below the freeze zone before turning toward the pool.

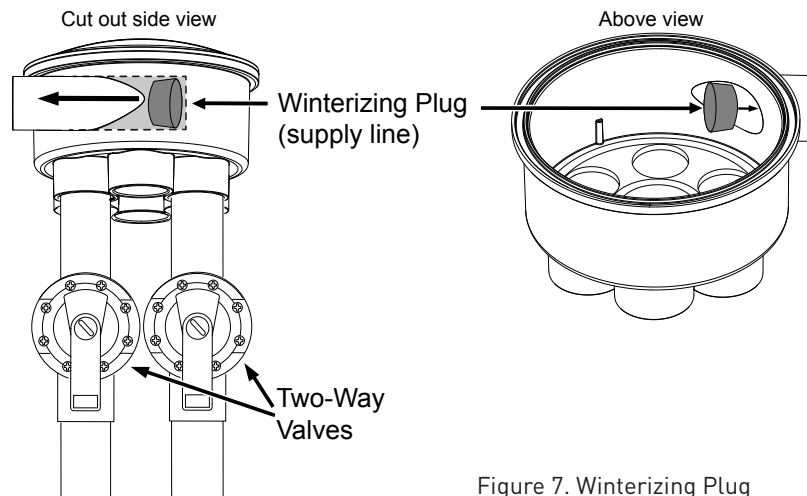

Figure 7. Winterizing Plug



## Pressure Testing

Perform a Hydrostatic pressure test by filling each line and the 6-Port valve with water. Isolate the plumbing so that the filter, pump, and heater are not subjected to the pressure test. Ensure cassette assembly is removed. Install the o-ring, lid and band clamp and torque clamp to approx. 95 inch-pounds. Pressure-test the system at a minimum of 35 psi for 24-48 hours or as local code requires. Keep the water valve secure and under pressure throughout the construction process. When all connections are complete and it is clear that the system is holding pressure, backfill, tamp and level all trenches.

When performing hydrostatic pressure tests or when testing for external leaks of the completed filtration and plumbing system, ensure that the maximum pressure the system is subjected to does not exceed the maximum working pressure of any of the components within the system.

### ⚠ WARNING

When pressure testing a system with water, air is often trapped in the system during the filling process. Should the system fail, this trapped air can propel debris at a high speed and cause injury. Every effort to remove trapped air must be taken. Pressure testing applies only to the plumbing and not to the pool equipment such as the filters, pumps, and heaters. To minimize risk of severe injury or death the filters, pumps, and heaters should not be subjected to the piping pressurization test. Refer to the manufacturer's instructions for the pumps, filters, and heaters for instructions regarding the maximum pressures the pool equipment can be subjected to.

# 3

## Preparing the System

### Cut Stub-ups

1. Verify that the system is holding pressure (minimum of 35 psi), then relieve system pressure.
2. Verify all stub-ups are above the pool shell.
3. Cut each stub-up
  - **For 2" collars:** Cut ½" (1.3 cm) above the cement.
  - **For 2-1/2" collars:** Cut flush with the cement **Tip: Use the UltraFlex® Collar Template (part #1-17-7) (see Figure 8).**
4. **Use a sander/grinder to sand each stub-up smooth and level** with the shell finish to ensure proper glue adhesion with collar setting. Insert test plug in each stub-up.
5. Use a blower assembly unit (blower, check valve, air/water supply, and connectors) to blow out debris that can gather in the plumbing during the construction process. For technical assistance, contact Jandy In-Floor for assembly instructions. Turn on blower and water supply and direct the flow to one zone at a time.
6. Starting at the cleaning head farthest from the valve, remove test plug and flush the pipe, blocking and releasing pressure several times to ensure a clear line. Replace test plug and repeat for each riser.

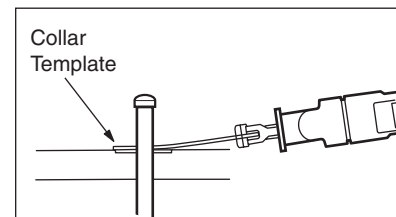

Figure 8. Riser Installation

### For Vinyl Liner Pools:

Set collar fittings before clearing lines.

1. Cut pipe stub-up flush with the pool floor. Then use an inside pipe cutter to cut it again 1 ⅞ in. (4.8 cm) lower than the floor level.
2. **Use ABS to PVC glue to secure the collar fitting. (Primer can be used on the pipe but not the fitting. Use glue on both.)** Insert collar to a full stop to ensure proper height.
3. Excavate an area (12 in. (30.5 cm) around head and 8 in. (20.3 cm) below excavated floor) and fill with concrete to form a "thrust block" to eliminate movement of the cleaning head.
4. Clear lines and insert test plugs limiting water use as there is no solid pool bottom.

## Install Collars

When the pool interior is completely clean and ready for the final finish application, install the collars (see Figure 9).

1. Set blue protective caps in collars.
2. Use heavy bodied PVC glue to secure the cleaning collars. (Primer can be used on the stub-ups but not the collars. **Use glue on both.**)
3. Push collar firmly into pipe with a 1/4 turn.
4. Ensure collar is perpendicular with pool shell; you can rotate the 2-1/2 Ultraflex® collar up to 10° to accommodate a crooked 2.5" stub-up.

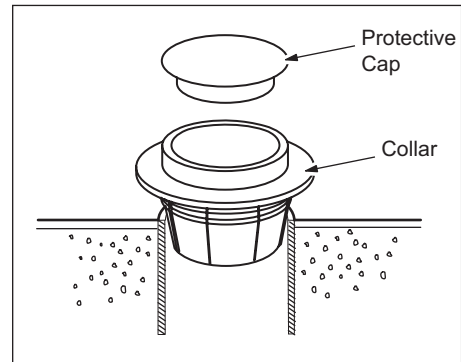

Figure 9. Collar Installation in a Gunite Pool

### For Vinyl Liner Pools:

Pool liner must be in final position before installing collars and cleaning heads (see Figure 10).

1. Press locking ring firmly into place in groove on collar fitting. **Installation Tip:** Turn collar upside down and use as a tool to press ring into place.
2. Use a razor knife to cut liner inside the locking ring, leaving at least a 1/4 in. (0.6 cm) edge around the ring perimeter.
3. Tighten the collar into the collar fitting, turning clockwise until the collar lip fits snugly against locking ring.
4. Insert Metal Combination Tool (part #3-17-7) into collar and rotate clockwise until collar is firmly seated.

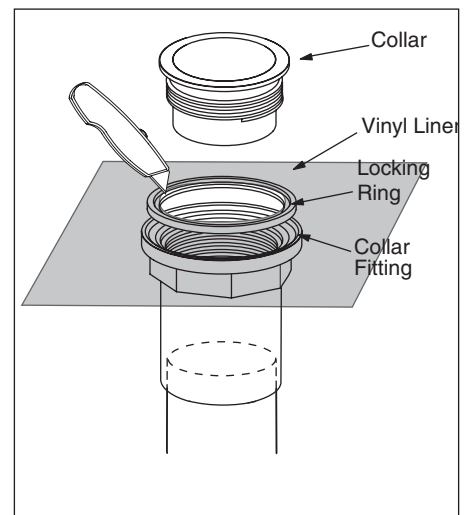

Figure 10. Collar Installation in a Vinyl Liner Pool

## Install Valve Cassette Assembly

Remove the band clamp and lid. (see Figure 11).

1. Install the cassette assembly.
2. Position o-ring in place and replace lid.
3. Replace band clamp and torque to approx. 95 inch-pounds. (tap on the perimeter periodically to ensure equal tension).
4. Turn on the system and check for leaks.

# 4

## Starting the System

Before initiating the system, open a discharge line before the valve and flush the pool pump and filtration system.

- Clear debris from all filters and pump basket.
- Remove the protective caps from the collars.
- **Run the in-floor system without cleaning heads installed for 24 hours to ensure the lines are clean.**

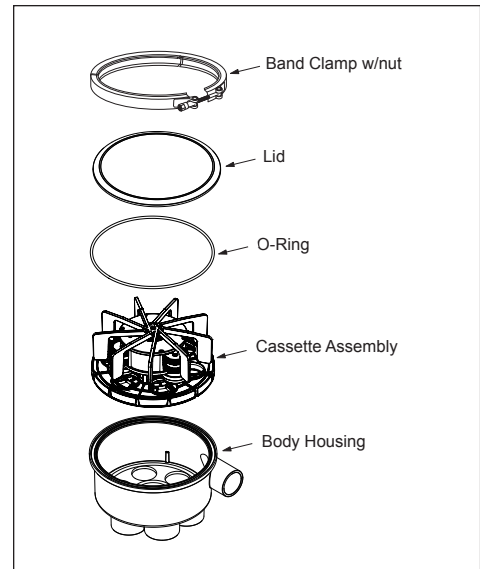

Figure 11. Installing the Functional Valve

# 5

## Install the Cleaning Heads

1. Install the nozzles into the cleaning head. Refer to the design plan to verify nozzle size.
2. Attach the Head Removal Tool (part #3-17-8) to the pool pole.
3. Snap tool into the head. Set head in collar; make sure the head is completely in the collar.
4. Turn clockwise (about 1/4 turn) to lock the head into position.
5. Lift straight up to release head from the removal tool.
6. Run the system for a complete cycle to confirm that all cleaning banks operate and that each head advances during pop-up and retraction.
7. Verify proper water pressure at the gauge near the water valve.  
Optimum level is 14-17 psi (97 - 152 kPa).

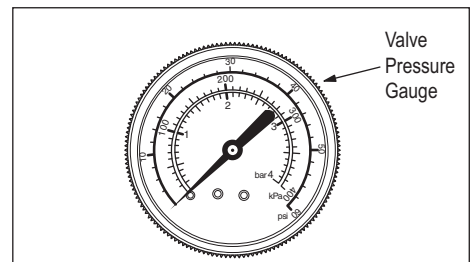

Figure 12. Valve Pressure Gauge

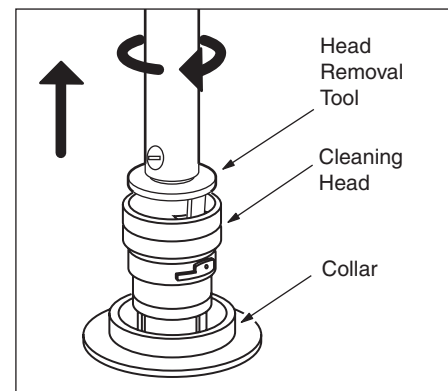

Figure 13. Installing Cleaning Heads

# Operation and Routine Maintenance

The Jandy In-Floor cleaning heads are designed to operate at a specific gallonage and pressure. To maintain flow through the heads, run the system whenever the pump is on.

Cleaning times will vary according to application and environment. To determine the optimum cleaning time, run the system 24 hours a day to start. Reduce run times by 2 hours every 2 days until minimum cleaning time is determined. Six hours a day is recommended.

Electrical cost savings can be gained by using a variable speed pump. The pump can be run through out the day at low RPM's, allowing water rotation through the filtration system. However, a high speed cleaning session will still be required to clean the floor of the pool.

Fine tune your system by finding the minimum speed required to fully lift the heads.

## Cleaning the Filtration System

For optimum cleaning efficiency, routinely clean the pool pump basket, skimmer and filter screens. Clean the pool filter whenever pressure increases 3 psi above normal clean-filter operating pressure. Refer to the manufacturer's instructions of the filter for proper cleaning instructions.

## Changing Cleaning Heads

**The cleaning head MUST be in the full down position before removal (see Figure 13).**

1. Attach the Head Removal Tool (part number 3-17-8) to the pool pole.
2. Snap tool into the head.
3. Turn counter-clockwise (1/4 of a turn) to release head from collar.
4. Pull and lift head out of collar.

To reinstall, simply insert head into collar and turn clockwise to lock it into position.

## Winterizing

### **⚠ CAUTION**

To prevent freeze damage in cold climates, remove water from the feed lines that are above the freeze line and seal the valve.

1. Remove the cassette assembly. Refer to instructions on Page 11.
2. Remove any cleaning heads located above the freeze line (step or bench heads).
3. Use compressor or blower to blow water from discharge lines.
4. Insert winterizing plugs into ports on the valve bottom or use 2-way valves on each line. (see page 8)
5. Place winterizing plugs into collars that are above water line to prevent runoff from filling the lines and refreezing.

# Troubleshooting

If the Jandy In-Floor cleaning system displays the following actions, adjustments may be necessary to restore performance. Refer to exploded parts diagram for part references.

**Action: Dirty spots appear.**

- Solution:
1. Clean the pool filter, pump basket, and skimmer baskets.
  2. Make sure all auxiliary valves (surface returns, waterfall, spa overflow, etc.) are closed.
  3. Ensure proper pressure, heads are rotating, proper nozzles are installed, and valve is rotating from zone to zone.

**Action: Dirt is trapped between heads.**

- Solution:
1. Verify that the heads on each side of dirt are pointed in the same direction. Advance a head, if necessary, using the head removal tool to ratchet the head up and down until nozzle points in the correct direction.
  2. Increase the cleaning time.
  3. May need to flow balance.

**Action: Cleaning head advances, but is not cleaning.**

- Solution:
1. Check for debris in the nozzle.
  2. Remove cleaning head and run pump for two (2) full cycles on problem bank. Check nozzle and reinstall head.

**Action: Cleaning head will not pop up or does not go down.**

- Solution:
1. Remove the head. Inspect the cleaning head and collar for plaster remnants or debris.
  2. With system running on the problem bank, lightly depress the problem head using a telescoping pool pole.

**Action: Pressure is lower than normal.**

- Solution:
1. Clean the pool filter, pump basket, and skimmer baskets.
  2. Make sure all auxiliary valves (surface returns, waterfall, spa overflow, etc.) are closed.
  3. Confirm that the pool pump is operating normally.
  4. Verify that the valve plate is completely over a port.

**Action: The 6-Port valve does not cycle.**

- Solution:
1. Clean the pool filter, pump basket and skimmer baskets.
  2. Make sure all auxiliary valves (surface returns, waterfall, spa overflow, etc.) are closed.
  3. Check pressure gauge on supply line to ensure that you have water flowing to the valve. Pressure should be 14-17 PSI.
  4. Turn pump on and off several times to clear system.
  5. Remove cassette and rotate fan by hand to check that the gears are functioning properly.
  6. If necessary, use part number WK000033 to replace the cassette assembly.

# REVOLUTION™

## 6-PORT VALVE

NO.	PART #	DESCRIPTION	QTY
1	WK000029	Band Clamp	1
2	WK000031	Housing Lid	1
3	WK000032	O-Ring	1
4	WK000033	Cassette Assembly	1
5	WK000034	Body Housin	1
6	WK000035	Gauge Assembly	1

**WARNING:**  
**Disassembly of the cassette**  
**may void the warranty.**

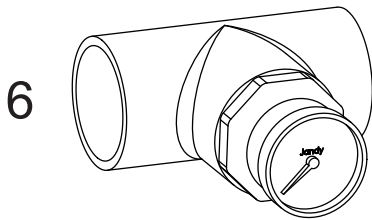

Cassette Assembly

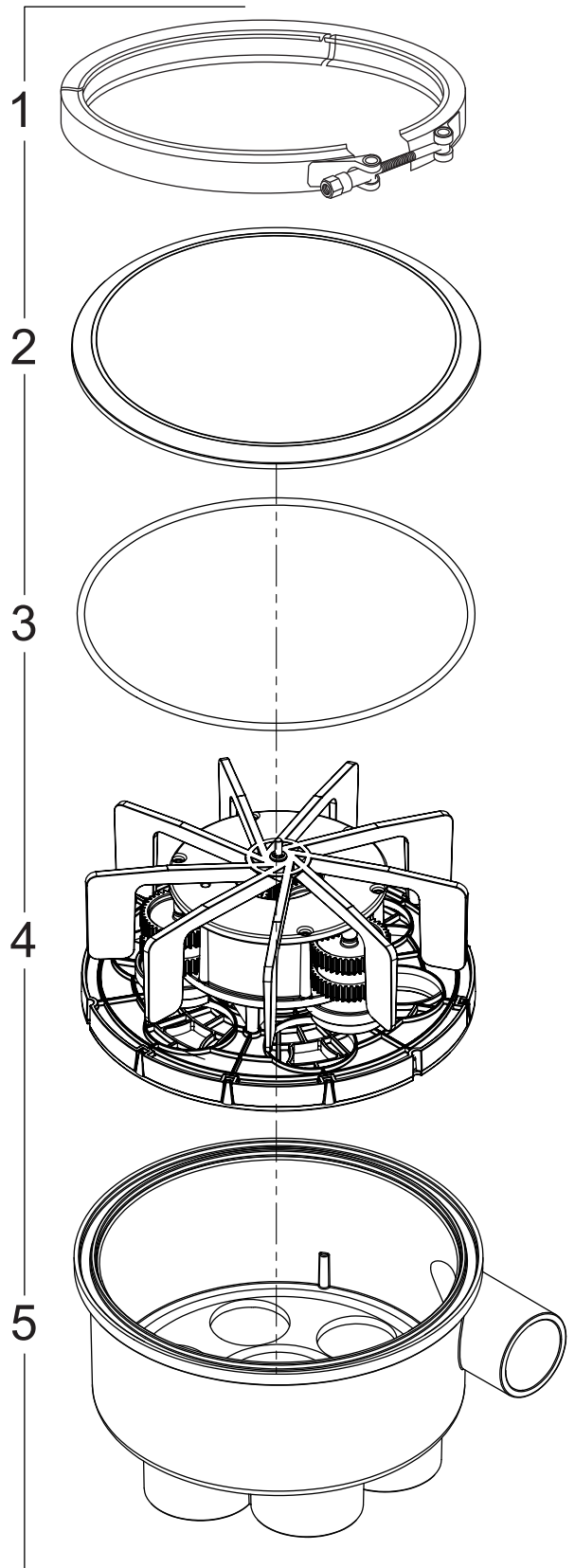
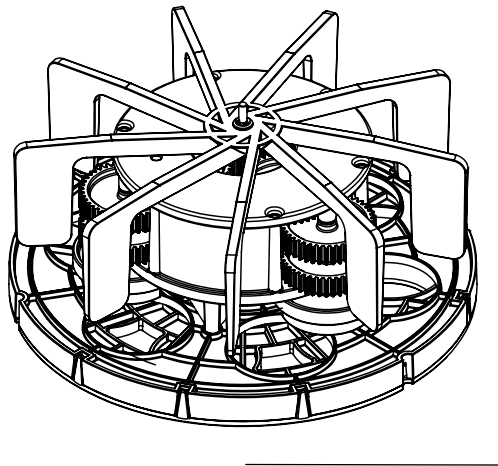

## Notes



2580 S Decker Lake Blvd, STE 300 West Valley City, UT 84119  
855.280.6465 toll-free | 801.906.6701 fax  
jandyinfloor.custsupport@fluidra.com  
Jandy.com/in-floor