

Hi-E2 Pool Heater Combustion Blower Replacement Kit

FOR YOUR SAFETY: This product must be installed and serviced by a professional service technician, qualified in pool/spa heater installation and maintenance. Improper installation and/or operation could create carbon monoxide gas in flue gases which could cause serious injury, property damage, or death. Improper installation and/or operation will void the warranty.

These instructions are to be used with Jandy Replacement Kit R0308200.

⚠ WARNING

If the information in these instructions is not followed exactly, a fire or explosion may result causing property damage, personal injury or loss of life.

This document provides instructions for replacement and adjustment of the combustion blower in Hi-E2 pool heaters (models EHE 220 and EHE 350). These instructions must be followed exactly. Read them completely before replacing the blower.

A. General Information

When a Hi-E2 combustion blower is replaced, three issues are of special importance:

1. Mechanical connection and sealing.
2. Electrical connection.
3. Speed adjustment.

B. Removal of Old Blower

⚠ WARNING

Disconnect electrical power before servicing. Failure to do so may result in an electrical shock hazard which can cause serious injury or death.

First, *disconnect electrical power from the heater*. Then unplug the black and white wires from the motor by pulling the connector out of the motor. Disconnect the green grounding wire by loosening the screw at the heater frame and pulling it free.

Loosen both screws of the clamp at the blower outlet. Slide the clamp upward onto the vent duct and fold the sleeve up on itself to disconnect it from the blower. Remove the three screws holding the blower to the collector, supporting the blower as necessary while

doing so. Remove the blower and clean the collector surface of any remaining adhesive or gasket fragments. Remove the rubber band sleeve from the bottom of the vent duct. Do not disconnect the vent duct from the top of the heater.

C. Installation of New Blower - Mechanical Connection and Sealing

First, fasten the self-adhesive gasket to the blower inlet. Place the replacement rubber sleeve on the bottom of the vent duct and temporarily fold it up on itself. Open the clamp so that it is very loose and place it over the blower outlet. Position the blower and inlet gasket on the collector, align all components and install the mounting screws. Push the clamp up, fold the rubber sleeve down over the blower outlet and position both to assure good alignment and sealing. Tighten the clamp screws. Inspect the entire installation (including connections at heater top and external vent piping) to assure that there are no leaks.

D. Electrical Connection

A green wire is provided with the replacement blower and the motor has a pre-punched hole to receive a screw for fastening this wire. The hole is on the motor end (opposite blower inlet) and is sometimes hidden by the label. If so, scrape the label material away to expose the hole. Attach the ring end of the wire to the blower motor with the 8-32 x3/8" screw provided. Place the star washer between the ring terminal and the motor. Fasten the other end of the green wire under the screw of the heater frame. Plug the power connector into the motor receptacle.

E. Speed Adjustment

It is usually necessary to adjust blower speed. If this is not done, the heater may not operate at the designed firing rate.

Combustion blower speed is adjusted by turning a special screw on the right side of the motor - at about 4 o'clock. A small countersunk hole is provided there for access to the screw. A small flat-blade screwdriver is required. It must have a 3/32" or 2.5mm (.098") flat blade and must be about 4-1/2" long. A jeweler's screwdriver or an electronics pot adjustment screwdriver (with handle cut short if necessary) can be used.

Adjustment of blower speed requires several steps per the following sections. The heater is first operated with the gas off, and after preliminary adjustment, with the gas on.

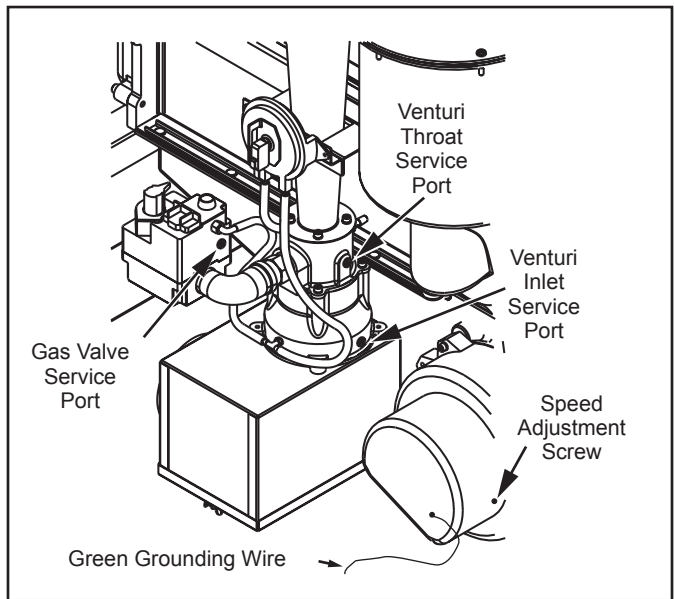

Figure 1. Venturi Flow System Components.

E-1. Pressure Measurement Ports

Figure 1 shows venturi and gas control components and service port locations. Air flow enters the venturi from below through the filter box. It is pulled through a converging section to the throat, where pressure is reduced substantially. Gas flow is pulled into the throat through an orifice inside the pipe between the throat and the elbow. Air and gas are combined in the throat and mix thoroughly as they proceed through the venturi tailpipe to the burner.

Service ports are provided at three places. On the right side of the venturi, an inlet service port is provided just above the air filter box. Also on the right side, a throat service port is provided - at the narrowest section of the venturi casting. A gas pressure port is provided on the outlet face (right side) of the gas valve.

To evaluate system operation requires accurate measurement at these ports. A digital manometer, known to be accurately calibrated, is ideal. Other instruments may be used, but the "positive/negative" nature of the readings must be very clear. Also, gas pressure offset measurements are at very low levels (0.2" WC) and the instruments must be capable of determining it accurately.

E-2. Unfired Venturi Differential

Before firing the unit, determine if the air flow through the system is normal by operating the system with the gas valve turned off. Connect the positive side of the manometer to the venturi inlet port, which is at the bottom on the right side. Connect the negative side of the manometer to the outlet pressure port of the gas valve (see Figure 2). Turn the gas valve knob to "Off". Turn the heater on by selecting "Pool" or "Spa" at the Flex Temp control and adjusting the temperature

setting high. The blower will start immediately and the manometer will indicate the "unfired venturi differential" pressure. This is the pressure difference created by airflow through the venturi. It should be approximately $4.7" \pm 0.3"$ at sea level. (See "Operation at High Elevation" when installation is more than 2000 feet above sea level.)

If the reading is not acceptable, insert the screwdriver through the hole on the motor housing and adjust the blower speed. Turn screw clockwise to increase the flow and counter-clockwise to decrease it. Note that when the heater is operated with the gas valve off, it will eventually "lock out" because the ignition control does not sense flame. If this happens before the adjustment can be made, turn the selector switch to "Off" and then back to "Pool" or "Spa" to start a new cycle.

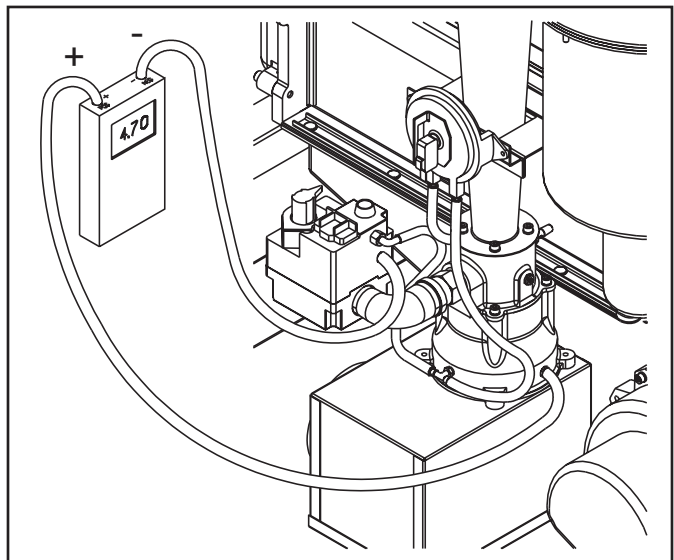

Figure 2. Unfired Venturi Differential Measurement

E-3. Gas Pressure Offset

Note that an equalizer tube is connected from a port on the front of the venturi inlet to the vent of the gas valve regulator. This is a very important component which allows the regulator to track air pressure even when abnormal things occur, such as blockage of the combustion air. Before firing, confirm that this tube and the venturi pressure switch tubes are in place and firmly connected.

Turn the heater off at the Flex Temp control. Turn the gas valve knob back to "On". With the manometer connections remaining as they were (see Figure 3), start the heater at the Flex Temp control. When the burner fires, the manometer should read 0.2 ± 0.1 " WC - i.e. gas pressure is 0.2 " WC less than venturi inlet pressure. If the offset is incorrect, adjust the gas valve pressure regulator to the correct pressure. This can usually be done while the heater is firing, but the burner may go off when the regulator seal cap is removed. In any case, the offset pressure measurement must be read *when the heater is operating and the seal cap is firmly in place*. Note that a special tool is required to remove the regulator cap.

Figure 4 shows the gas pressure offset reading when a U-Tube manometer is used.

⚠WARNING

In order to discourage incorrect adjustment by unqualified persons, the gas valve regulator cap requires a special tool for removal. Contact your representative about a special tool for this cap.

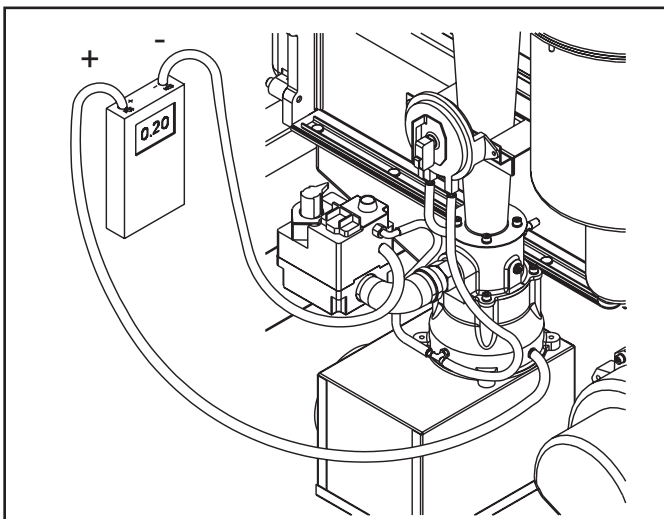

Figure 3. Gas Pressure Offset Measurement

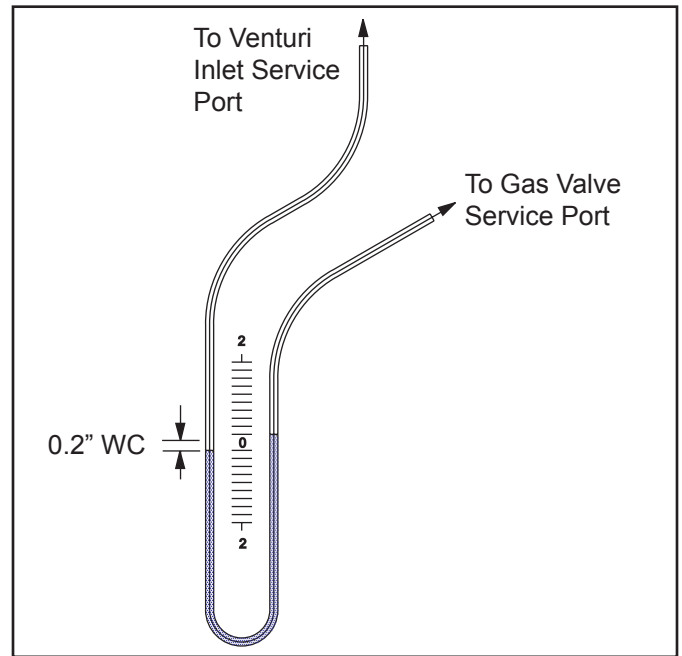

Figure 4. Gas Pressure Offset Measurement with U-Tube Manometer

E-4. Gas Orifice Differential

Turn off the heater, disconnect the manometer tubes and replace the plug at the venturi inlet. Reconnect the tubes with the positive side of the manometer connected to the gas valve outlet and the negative side to the venturi throat as shown in Figure 5.

Turn on the heater. The manometer will read zero until the gas valve opens. Thereafter it should read 4.0 ± 0.3 " WC.

Using the screwdriver as before, adjust the speed as necessary to obtain this reading. After adjusting apply the silver-colored "anti-tamper" label over the adjustment hole.

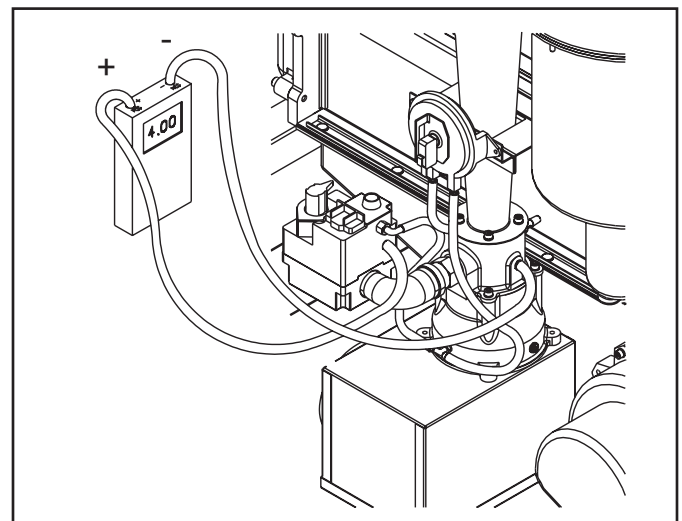

Figure 5. Gas Orifice Differential Measurement

E-5. Operation at High Elevation

In servicing a Hi-E2 heater at high elevation, be aware that the differential pressures, as discussed in prior sections, will be reduced. Pressure readings at various elevations will be approximately as follows:

Elevation Ft. (m)	Gas Orifice Differential	Unfired Venturi Differential
Sea Level	4.0" (102mm)WC	4.7" (119mm) WC
2000 (610)	3.7 (94)	4.3 (109)
4000 (1220)	3.4 (86)	4.0 (102)
6000 (1830)	3.2 (81)	3.7 (94)
8000 (2440)	2.9 (74)	3.5 (89)
10000 (3050)	2.7 (69)	3.2 (81)

The gas pressure offset is determined by the regulator spring adjustment, not air density. It is not affected by elevation changes.

Parts List

Description	Quantity
Combustion Blower	1
Green Wire Assembly	1
Gasket, Fan Inlet	1
Rubber Sleeve	1
Screw, #10 - 32 x 1-1/2	3
Lockwasher, External Star, #10	3
Screw, #8 - 32 x 3/8	1
Lockwasher, External Star, #8	1
Label, Anti-Tamper, Silver	1
Installation Instructions, Hi-E2 Blower	1

Jandy®, Lite®, LX® and HI-E2® are registered trademarks of Jandy Pool Products, Inc.
All other brand names, products names or trademarks belong to their respective holders.



Jandy Pool Products, Inc.
6000 Condor Drive, Moorpark, CA, USA 93021 • 707.776.8200 FAX 707.763.7785
1758 Corporate Circle, Petaluma, CA, USA 94954 • 707.776.8200 FAX 707.763.7785