

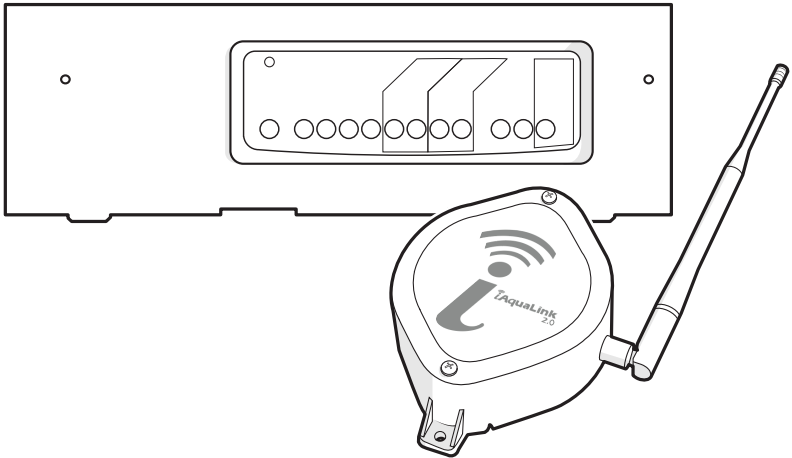

AquaLink® RS Conversion Kit for Pentair® Enclosures Installation Instructions



⚠ WARNING

FOR YOUR SAFETY - This product must be installed and serviced by a contractor who is licensed and qualified in pool equipment by the jurisdiction in which the product will be installed where such state or local requirements exist, the maintainer must be a professional with sufficient experience in pool equipment installation and maintenance so that all of the instructions in this manual can be followed exactly. Before installing this product, read and follow all warning notices and instructions that accompany this product. Failure to follow warning notices and instructions may result in property damage, personal injury, or death. Improper installation and/or operation may void the warranty. Improper installation and/or operation can create unwanted electrical hazard which can cause serious injury, property damage, or death. Turn off all circuit breakers required in order to prevent the possibility of electric shock



ATTENTION INSTALLER: This manual contains important information about the installation, operation and safe use of this product. This information should be given to the owner/operator of this equipment.

Table of Contents

Section 1.	Important Safety Instructions.....	3
Section 2.	Package Contents	4
2.1	Pool Pump Suction Entrapment Prevention Guidelines	7
2.2	Package Contents.....	9
Section 3.	Product Compatibility.....	10
Section 4.	Remove the Pentair® Control Panel	11
4.1	Transformer located on low voltage side.....	11
4.2	Transformer located on high voltage side	14
Section 5.	Install the AquaLink RS Conversion Kit.....	16
5.1	Apply the New Wiring Label	16
5.2	New Transformer Installation	17
5.3	Install Conversion Kit.....	18
5.4	Connect Sensor Wires	19
5.5	Connecting Heater to Low Voltage Wiring	19
5.6	Connecting Auxilliary Equipment to PCB.....	20
5.7	Finalize Hardware Installation	20
5.8	Test the Equipment	21
Section 6.	Program DIP Switch Settings	21
6.1	DIP Switch Functions.....	21
6.2	DIP Switch Settings	23
6.3	DIP Switch Settings for Solar/Heat Pump.....	24
Section 7.	Install and Program the iQ20.....	25

Section 1. Important Safety Instructions

READ AND FOLLOW ALL INSTRUCTIONS

All electrical work must be performed by a licensed electrician and conform to all national, state, and local codes. When installing and using this electrical equipment, basic safety precautions should always be followed, including the following:

WARNING

EQUIPMENT UNDER PRESSURE:

Always turn pump off prior to installation or service. Your pump/filter system is operated under pressure and the pressure must be released before you begin work. Please see your pump/filter owner's manual for further instructions.

WARNING

To reduce the risk of electric shock, fire or injury, service should only be attempted by a qualified pool service professional.

Risk of electric shock: Install the power center at least five (5) feet (1.52 m) from the inside wall of the pool and/or hot tub using non-metallic plumbing. Canadian installations must be at least three (3) meters from the water.

WARNING

Risk of electric shock which can result in serious injury or loss of life: Before attempting to install or service, ensure that all power to the circuit supplying power to the system is disconnected or turned off at the circuit breaker. All wiring must be done in accordance with the National Electrical Code® (NEC)®, NFPA-70®, including those in Article 680 - Swimming Pools, Fountains, and Similar Installations.

In Canada, the Canadian Electrical Code (CEC), CSA C22.1, must be followed. All applicable local installation codes and regulations must be followed.

ATTENTION: The power center and the chlorine generator control center are not to be considered as suitable for use as service equipment. Therefore, it is required to have the appropriate means of disconnection, circuit isolation, and/or branch circuit

protection installed upstream of the power/control center

WARNING

To reduce the risk of injury do not permit children to use this product unless they are closely supervised at all times.

WARNING

Risk of Accidental Drowning. Extreme caution must be exercised to prevent unauthorized access by children. To avoid accidents, ensure that children cannot use a spa or hot tub unless they are closely supervised at all times.

This appliance is not intended for use by persons (including children) with reduced physical, sensory or mental capabilities, or lack of experience and knowledge, unless they have been given supervision or instruction concerning use of the appliance by a person responsible for their safety.

PREVENT CHILD DROWNING:

Do not let anyone, especially small children, sit, step, lean or climb on any equipment installed as part of your pool's operational system. Locate the components of your operational system at least 1 m (3 ft 3 in) from the pool so children cannot use the equipment to access the pool and be injured or drown.

To reduce the risk of injury, do not remove the suction fittings of your spa or hot tub. Never operate a spa or hot tub if the suction fittings are broken or missing. Never replace a suction fitting with one rated less than the flow rate marked on the equipment assembly.

Section 2. Package Contents

WARNING

To avoid injury ensure that you use this control system to control only packaged pool/spa heaters which have built-in operating and high limit controls to limit water temperature for pool/spa applications. This device should not be relied upon as a safety limit control. Water temperature in excess of 100°F (38°C) may be hazardous to your health.

WARNING

A terminal bar marked "GROUND" is provided within the power center. To reduce the risk of electrical shock, connect this terminal bar to the grounding terminal of your electric service or supply panel with a continuous copper conductor having green insulation and one that is equivalent in size to the circuit conductors supplying this equipment, but no smaller than no. 12 AWG (3.3 mm²). In addition, a second wire connector should be bonded with a no. 8 AWG (8.4 mm²) copper wire to any metal ladders, water pipes, or other metal within five (5) feet (1.52 m) of the pool/spa. In Canada, the bonding wire must be minimum 6 AWG (13,3 mm²).

WARNING

A ground-fault circuit-interrupter must be provided if this device is used to control underwater lighting fixtures. The conductors on the load side of the ground-fault circuit-interrupter shall not occupy conduit, boxes, or enclosures containing other conductors unless the additional conductors are also protected by a ground-fault circuit-interrupter. Refer to local codes for complete details.

CAUTION: This device is intended for use with permanent swimming pools and may also be used with hot tubs and spas if so marked. Do not use with storable pools. A permanently-installed pool is constructed in or on the ground or in a building such that it cannot be readily disassembled for storage. A storable pool is constructed so that it is capable of being readily disassembled for storage and reassembled to its original integrity.

When mixing acid or other chemicals with water, **ALWAYS ADD THE ACID OR CHEMICALS TO WATER. NEVER ADD WATER TO THE ACID OR CHEMICALS.**

CAUTION: It is important to note that certain materials used in and around swimming pools and spas may not be compatible with chemicals commonly used to purify pool and spa water (e.g. acids, chlorine, salt, stabilizers, etc.).

Zodiac Pool Systems LLC does not warrant or guarantee that the chlorinated water generated by the Jandy® Pro Series chlorine generating device will not damage or destroy certain types of plants, decking, coping and other materials in and around your pool and/or spa. Before selecting materials to be used in and around your pool and/or spa, please discuss all options with your contractor to assess the compatibility of such materials and chemicals.

Some helpful considerations may include:

- Choosing plants that can withstand splash out of pool water containing chlorine and/or salt and other water purification chemicals.

- All metal components used in and around a pool should be of a high grade, quality stainless steel.
- Careful selection of masonry products. The porosity and hardness of natural stones varies greatly. Therefore we recommend you consult with your builder or stone contractor on the best choice for stone materials around your pool or spa.
- Sealing all masonry products. Professionals in the stone industry specify that even natural stone, especially when used outdoors, be sealed to prevent weathering, staining, and premature degradation. Consult with your stone or deck contractor for the proper sealer for the masonry products you have selected to use around your pool or spa.
- For optimal results, sealers should be reapplied on a regular basis. Reapply the protective sealer on a schedule per the manufacturer's instructions.
- Use of chemicals other than those recommended may be hazardous. Follow the chemical manufacturers instructions.

WARNING

Prolonged immersion in hot water may induce hyperthermia. Hyperthermia occurs when the internal temperature of the body reaches a level several degrees above the normal body temperature of 37 °C (98.6 °F). The symptoms of hyperthermia include dizziness, fainting, drowsiness, lethargy, and an increase in the internal temperature of the body. The effects of hyperthermia include:

- Unawareness of impending danger
- Failure to perceive heat
- Failure to recognize the need to exit spa
- Physical inability to exit spa
- Fetal damage in pregnant women

- Unconsciousness resulting in a danger of drowning

To Reduce the Risk of Injury:

- The water in a spa should never exceed 40°C (104°F). Water temperatures between 38°C (100°F) and 40°C (104°F) are considered safe for a healthy adult. Lower water temperatures are recommended for young children and when spa use exceeds 10 minutes.
- Since excessive water temperatures have a high potential for causing fetal damage during the early months of pregnancy, pregnant or possibly pregnant women should limit spa water temperatures to 38°C (100°F).
- Before entering a spa or hot tub, the user should measure the water temperature with an accurate thermometer since the tolerance of water temperature-regulating devices varies.
- The use of alcohol, drugs, or medication before or during spa or hot tub use may lead to unconsciousness with the possibility of drowning.
- Obese persons and persons with a history of heart disease, low or high blood pressure, circulatory system problems, or diabetes should consult a physician before using a spa.
- Persons using medication should consult a physician before using a spa or hot tub since some medication may induce drowsiness while other medication may affect heart rate, blood pressure, and circulation.
- People with infectious diseases should not use a spa or hot tub.
- To avoid injury, exercise care when entering or exiting the spa or hot tub.

- Do not use drugs or alcohol before or during the use of a spa or hot tub to avoid unconsciousness and possible drowning.
- Pregnant or possibly pregnant women should consult a physician before using a spa or hot tub.
- Water temperature in excess of 38°C (100°F) may be injurious to your health.
- Before entering a spa or hot tub measure the water temperature with an accurate thermometer.
- Do not use a spa or hot tub immediately following strenuous exercise.
- Prolonged immersion in a spa or hot tub may be injurious to your health.
- Do not permit any electric appliance (such as a light, telephone, radio, or television) within 1.5 m (5 ft.) of a spa or hot tub.
- The use of alcohol, drugs or medication can greatly increase the risk of fatal hyperthermia in hot tubs and spas.
- Operating a chlorine generator without water flowing through the cell may cause a build up of flammable gases, resulting in fire or explosion.
- Keep equipment out of reach of children.
- A damaged supply cord should only be replaced by the manufacturer, service agent or electrician.
- When installing and using this electrical equipment, always follow basic safety precautions.
- Before performing installation, disconnect all power.
- Connect to a circuit that is protected by a ground-fault circuit interrupter (GFCI).
- Do not install within an outer enclosure or beneath the skirt of a hot tub or spa.

WARNING

Improper gas heater installation or maintenance can cause nausea or asphyxiation from carbon monoxide in flue gases which could result in severe injury, or death. For indoor installations, as an additional measure of safety, Zodiac Pool Systems LLC strongly recommends installation of suitable Carbon Monoxide detectors in the vicinity of this appliance and in any adjacent occupied spaces.

WARNING

Jandy® Pro Series chlorine generating devices are designed for domestic (residential) swimming pool use only. Contrary use could affect performance, void warranty, and may result in property damage, serious injury, or death.

ATTENTION: This device complies with part 15 of the FCC Rules. Operation is subject to the following two conditions: (1) This device may not cause harmful interference, and (2) this device must accept any interference received, including interference that may cause undesired operation. This device must be installed to provide a separation distance of at least 20cm from all persons and must not be collocated or operating in conjunction with any other antenna or transmitter, except in accordance with FCC multi-transmitter product guidelines.

NOTE: This equipment has been tested and found to comply with the limits for a Class B digital device, pursuant to part 15 of the FCC Rules. These limits are designed to provide reasonable protection against harmful interference in a residential installation. This equipment generates, uses and can radiate radio frequency energy and, if not installed and used in accordance with the instructions, may cause harmful interference to radio communications.

However, there is no guarantee that interference will not occur in a particular installation. If this equipment does cause harmful interference to radio or television reception, which can be determined by turning the equipment off and on, the user is encouraged to try to correct the interference by one or more of the following measures:

- Reorient or relocate the receiving antenna.
- Increase the separation between the equipment and receiver.
- Connect the equipment to an electrical source on a circuit different from that to which the receiver is connected.
- Consult the dealer or an experienced radio/TV technician for help.

Modifications made to this equipment, which are not authorized by the manufacturer, may void the user's authority to operate this equipment.

This device contains license-exempt transmitter(s)/receiver(s) that comply with Innovation, Science and Economic Development Canada's license-exempt RSS(s) Operation is subject to the following two conditions: (1) This device may not cause interference. (2) This device must accept any interference, including interference that may cause undesired operation of the device.

2.1 Pool Pump Suction Entrapment Prevention Guidelines

WARNING

Pump suction is hazardous and can trap and drown or disembowel bathers. Do not use or operate swimming pools, spa, or hot tubs if a suction outlet cover is missing, broken, or loose: The following guidelines provide information for pump installation that minimizes the risk of injury to users of pools, spas, and hot tubs:

Entrapment Protection: The pump suction system must provide protection against the hazards of suction entrapment.

Suction Outlet Covers: All suction outlets must have correctly installed, screw-fastened covers in place. All suction outlet (drain) covers must be maintained. Drain covers must be listed/certified to the latest version of ANSI®/ASME® A112.19.8 or its successor standard, ANSI/APSP-16. They must be replaced if cracked, broken, or missing.

Number of Suction Outlets Per Pump: Provide at least two (2) hydraulically-balanced main drains, with covers, as suction outlets for each circulating

pump suction line. The centers of the main drains (suction outlets) on any one (1) suction line must be at least three (3) feet apart, center to center. See Figure 1.

The system **must** be built to include at least two (2) suction outlets (drains) connected to the pump whenever the pump is running. However, if two (2) main drains run into a single suction line, the single suction line may be equipped with a valve that will shut off both main drains from the pump. The system shall be constructed such that it shall not allow for separate or independent shutoff or isolation of each drain. See Figure 1.

More than one (1) pump can be connected to a single suction line as long as the requirements above are met.

Must comply with the latest version of ANSI/ASME A112.19.8 or its successor standard, ANSI/APSP-16, the standard for Suction Fittings For Use in Swimming Pools, Wading Pools, Spas, and Hot Tubs.

Water Velocity: The maximum water velocity through the suction fitting or cover for any suction outlet must be 1.5 feet per second unless the outlet complies with the latest version of ANSI/ASME A112.19.8 or its successor standard, ANSI/APSP-16, the standard for Suction Fittings For Use in Swimming Pools, Wading Pools, Spas, and Hot Tubs. In any case, do not exceed the suction fitting's maximum designed flow rate.

If 100% of the pump's flow comes from the main drain system, the maximum water velocity in the pump suction hydraulic system must be six (6) feet per second or less, even if one (1) main drain (suction outlet) is completely blocked. The flow through the remaining main drain(s) must comply with the latest version of ANSI/ASME A112.19.8 or its successor standard, ANSI/APSP-16, the standard for Suction Fittings For Use in Swimming Pools, Wading Pools, Spas, and Hot Tubs.

Testing and Certification: Suction outlet covers must have been tested by a nationally recognized testing laboratory and found to comply with the latest version of ANSI/ASME A112.19.8 or its successor standard, ANSI/APSP-16, the standard for Suction Fittings For Use in Swimming Pools, Wading Pools, Spas, and Hot Tubs.

Fittings: Fittings restrict flow; for best efficiency use fewest possible fittings (but at least two (2) suction outlets). Avoid fittings which could cause an air trap. Pool cleaner suction fittings must conform to applicable International Association of Plumbing and Mechanical Officials (IAPMO®) standards.

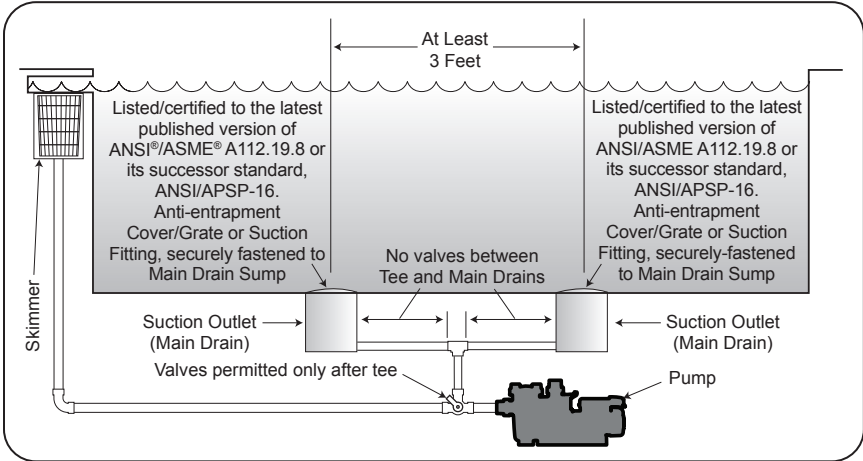

SAVE THESE INSTRUCTIONS

Aqualink RS Conversion Kit is ETL Classified to the following standards
UL 1563
CSA C22.2#218.1

2.2 Package Contents

Before starting, check that you have the correct parts as indicated below. If any parts are missing or incorrect, please call your local distributor or technical support at 1-800-822-7933 for assistance.

KIT		
Item	Description	QTY
1	AquaLink® RS System Level	1
2	Transformer	1
3	Transformer Bracket	1
4	PIB Bracket	1
5	System Level Board Hinge	1
6	iQ20 Web Connect Device	1
7	Low Voltage Dead Front	1
8*	Enclosure Conversion Wiring Diagram Label	1
9*	Professional Installation Required Label	1

*NOT SHOWN - The AquaLink RS Conversion Kit for Pentair® enclosures includes a wiring diagram overlay, button function/UI label and a sheet of user interface auxiliary labels.

Table 1. Kit Contents

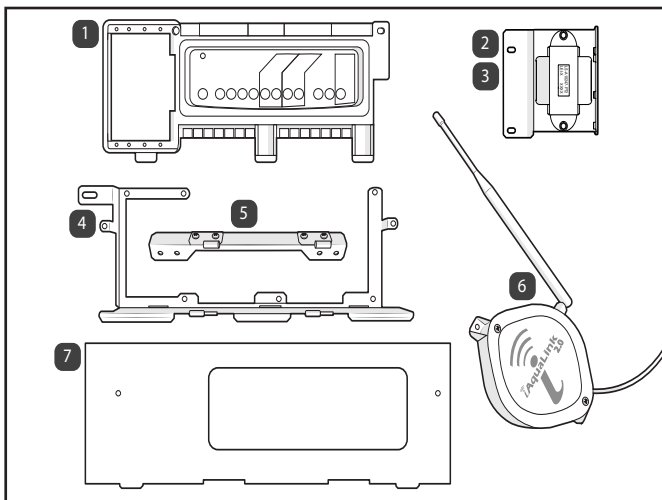

Figure 1. Kit Contents

Section 3. Product Compatibility

Please read before proceeding.

This conversion kit can be used on most versions of the following Pentair systems. Before beginning contact Fluidra technical support for validation on the specific system configuration and/or systems not referenced.

AquaLink RS Conversion Kit for use with the following equipment
EasyTouch®*
EasyTouch® PL4/PLS4
IntelliTouch®**
IntelliCenter®

*All respective brands and trademarks are property of Pentair Corporation.

** Replace with Jandy One Touch interface.

It is not recommended to use this conversion kit in conjunction with Pentair integrated Saltwater systems such as Intelichlor, or iChlor.

For configurations which have Pentair integrated Saltwater systems, replace the salt system with Jandy AquaPure or TruClear.

Section 4. Remove the Pentair® Control Panel

Before beginning the installation, verify the location has adequate WiFi coverage or a wired Ethernet connection to the home router. The AquaLink RS Conversion Kit uses a connection to the Internet. If Internet access is questionable or not functional, it is advised to not proceed with the Pentair control panel removal and changes until access is ensured.

NOTE Use of this AquaLink® RS Conversion Kit with Pentair® integrated Saltwater systems is not recommended. Refer to the compatibility section 3 of this manual before proceeding.

TIP: For faster AquaLink® RS set up and programming, use tape and a marker to tag each relay and valve connector, as you remove it, with the relay number, name, and function.

WARNING

Risk of electric shock which can result in serious injury or death: Before attempting to install or service, ensure that all power to the circuit supplying power to the system is disconnected or turned off at the circuit breaker. All wiring must be done in accordance with the National Electrical Code® (NEC)®, NFPA-7®.

In Canada, the Canadian Electrical Code (CEC), CSA C22.1, must be followed. All applicable local installation codes and regulations must be followed.

4.1 Transformer located in control panel compartment

1. Turn off power at the breaker panel.
2. Remove 2 retaining screws on top of the High Voltage cover panel, see Figure 2(a).

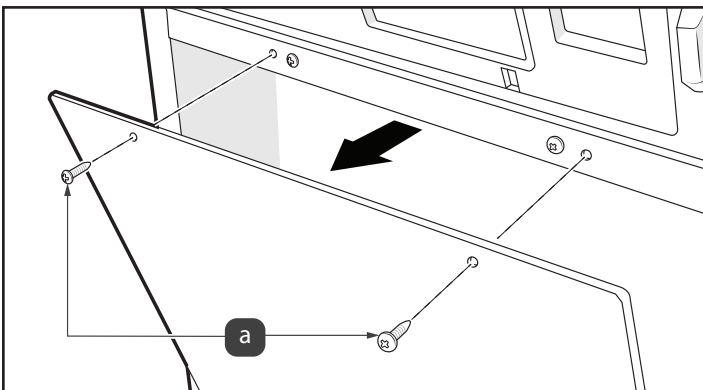

Figure 2. Remove Dead Front Screws

3. Remove the High Voltage cover panel from enclosure.
4. Remove power to transformer from either the relay or resettable fuses.

- Remove the top two screws on Pentair control panel, swing panel down to allow access to wiring behind it, see Figure 3(a).

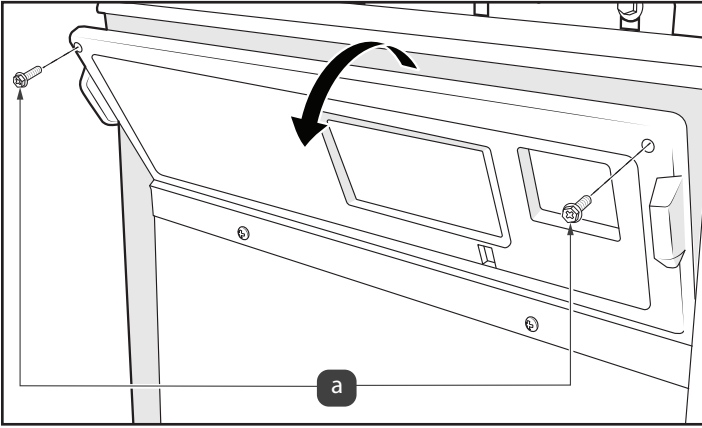

Figure 3. Remove Pentair Control Panel Screws

- Disconnect power connection from the transformer.
- Unplug valve actuator's, mark them intake and return.
- Disconnect the Ethernet cable, see Figure 4(a).
- Unplug the auxiliary relays, see Figure 4(b).

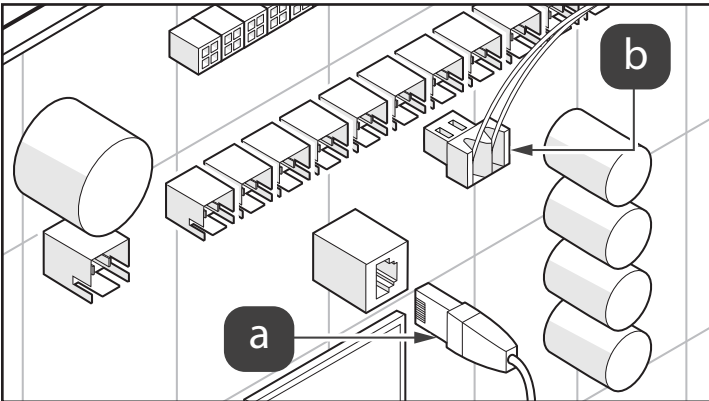

Figure 4. Unplug Auxiliary Relays

- Unplug RS-232, including saltboard if one exists. If salt removed, replace screws to maintain water tightness.
- Unplug spa controller (if installed).
- Disconnect all temperature sensors.
- Remove 2 inner retaining screws from transformer assembly, see Figure 5(a).

14. Remove 2 outer retaining screws from transformer assembly, see Figure 5(b).

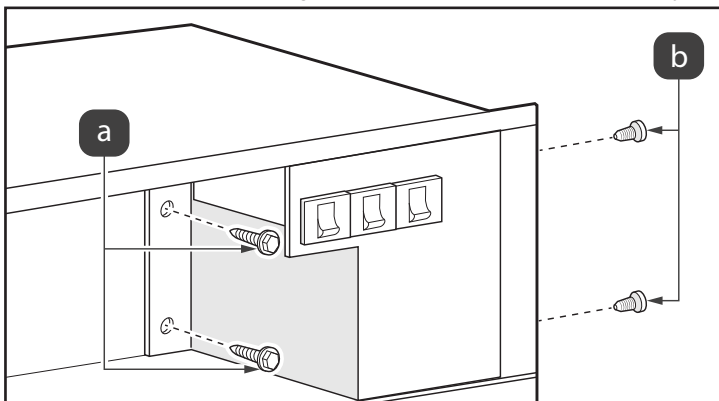

Figure 5. Remove Transformer Assembly

15. Remove old transformer from enclosure.

16. Remove 2 outer retaining screws on top of the High Voltage cover panel, see Figure 6(a).

17. Remove the High Voltage cover panel from enclosure.

18. Remove 2 inner retaining screws from Pentair® control panel, see Figure 6(b).

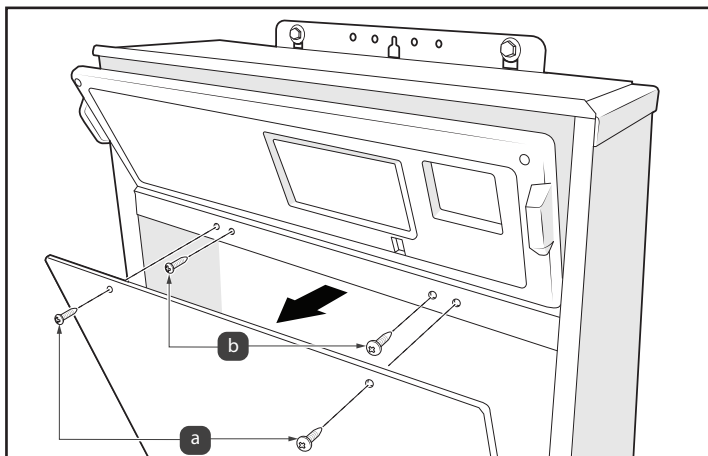

Figure 6. Remove Lower Screws

19. Remove Pentair® control panel from enclosure.

20. Remove salt board if one exists.

21. Remove IntelliClor® circuit breaker.

22. Remove or bend back circuit breaker mounting tab.

4.2 Transformer located on high voltage side

1. Turn off power at the breaker panel.
2. Remove 2 retaining screws on top of the High Voltage cover panel, see Figure 7(a).

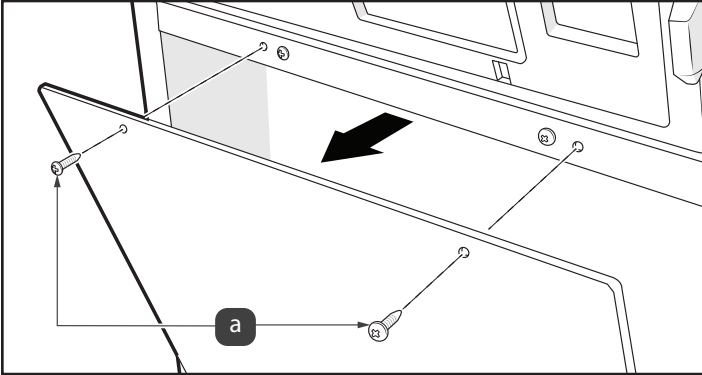

Figure 7. Remove Dead Front Screws

3. Remove the High Voltage cover panel from enclosure.
4. Locate existing transformer and unplug it.
5. Remove existing transformer wires from resettable fuses, see Figure 8(a)
6. Remove existing transformer retaining screws, see Figure 8(b)
7. Remove existing transformer and replace retaining screws back into holes.

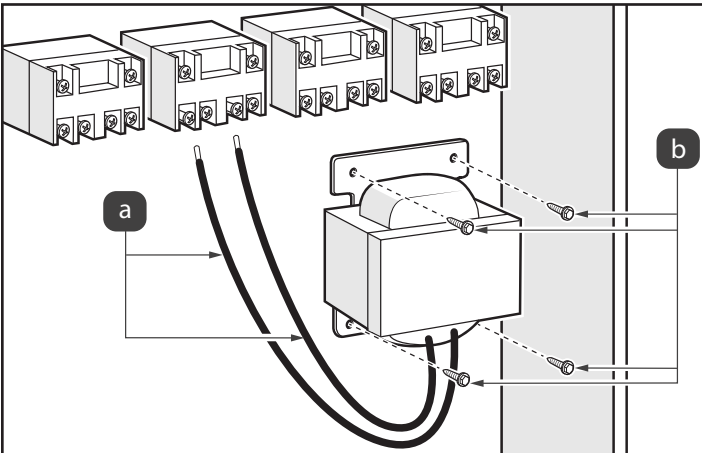

Figure 8. Remove Existing Transformer

- Remove the top two screws on Pentair control panel, swing panel down to allow access to wiring behind it, see Figure 9(a).

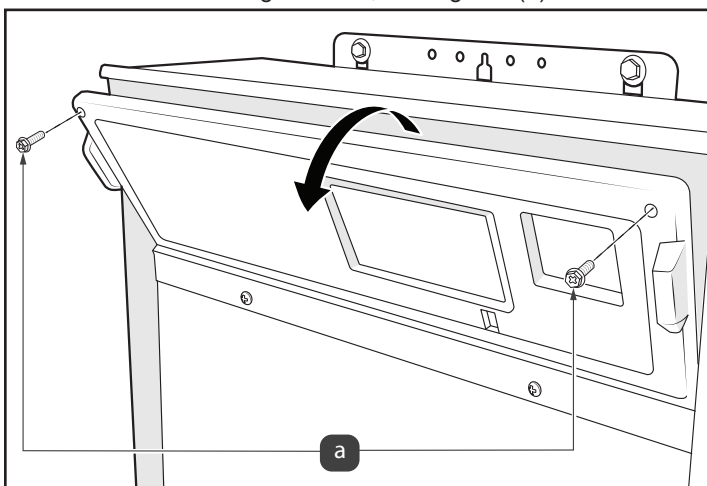

Figure 9. Remove Pentair® Control Panel Screws

- Disconnect power connection from the transformer.
- Unplug Valve actuator's, mark them intake and return.
- Disconnect the Ethernet cable, see Figure 10(a).
- Unplug the auxiliary relays, see Figure 10(b).

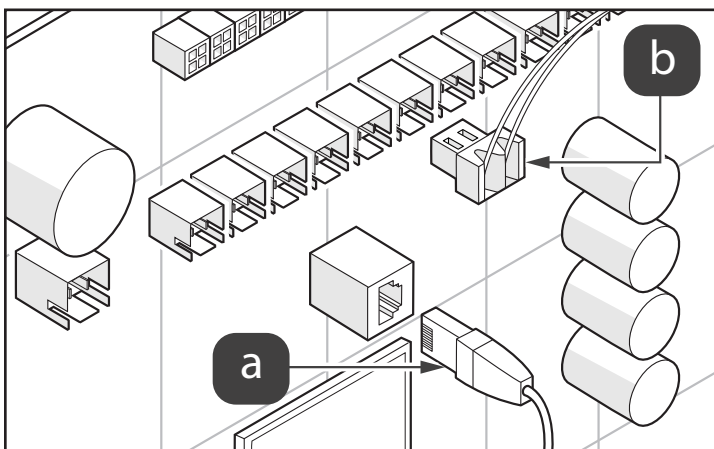

Figure 10. Unplug Auxiliary Relays

- Unplug RS-232, including saltboard if one exists.
- Unplug spa controller (if installed).

- 15. Disconnect all temperature sensors.
- 16. Remove the 3 retaining screws from circuit breaker assembly located behind control panel, see Figure 11(a).

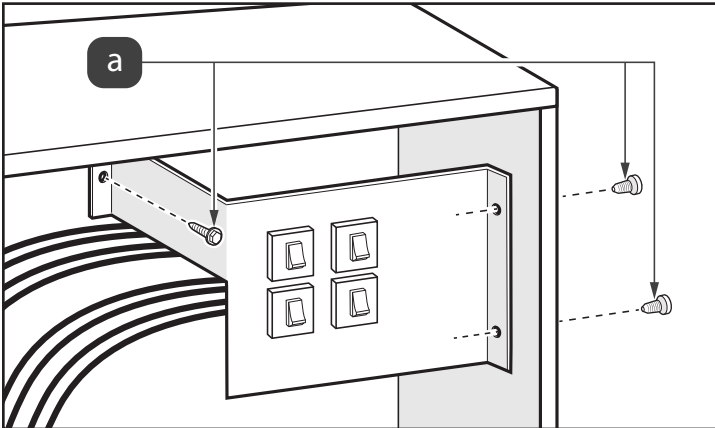

Figure 11. Remove Circuit Breaker Assembly

Section 5. Install the AquaLink® RS Conversion Kit

5.1 Apply the New Wiring Label

- 1. Place AquaLink RS Conversion wiring diagram label over existing Pentair® wiring diagram on the inside of the enclosure door. DO NOT COVER EXISTING PENTAIR WARNINGS OR RATING INFORMATION, see Figure 12(a).

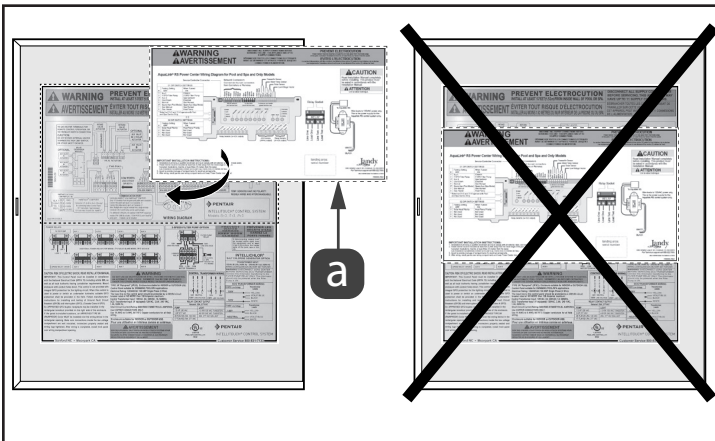

Figure 12. Warning Label

5.2 New Transformer Installation

⚠ CAUTION: The Jandy Aqualink transformer must be wired to 120V.

1. Use new transformer bracket to install new transformer in the control panel compartment, see Figure 13(a). Ensure all screw holes and openings not being used are properly closed off and sealed.
2. Wire new transformer to 120 VAC. If applicable, use supply previously connected to the Pentair® transformer.
3. Connect 120 VAC to the transformer. Line (black), Neutral (white), and ground (green).
4. Connect transformer output terminal to PCB board 24VAC input terminal.

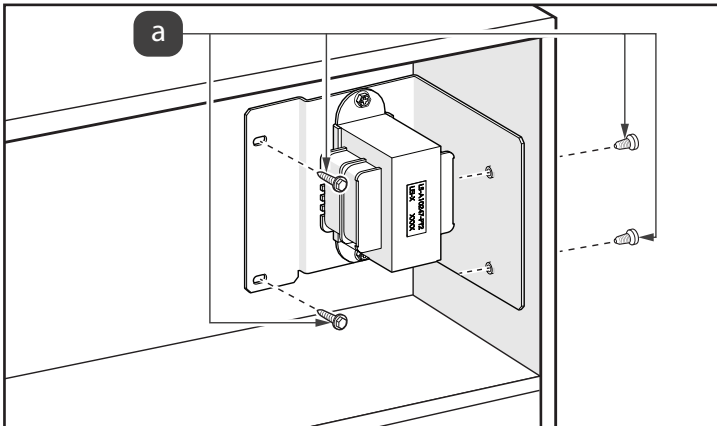

Figure 13 New Transformer Mounting

5.3 Install Conversion Kit

⚠ CAUTION If wiring is close to the top of metal enclosure, route the wiring, use wraps or ties, and add electrical insulating tape to ensure no contact is possible between wiring and metal enclosure.

1. Secure AquaLink® RS Conversion Kit hinge using the 2 retaining screws removed in section 2.4, see Figure 14(a)
2. Slide 3 tabs on AquaLink RS Conversion Kit PIB into the slots in bracket, see Figure 14(b).
3. Secure AquaLink RS Conversion Kit PIB onto bracket with 2 top screws.
4. Slide pins on AquaLink RS Conversion Kit into hinge, see Figure 14(c).

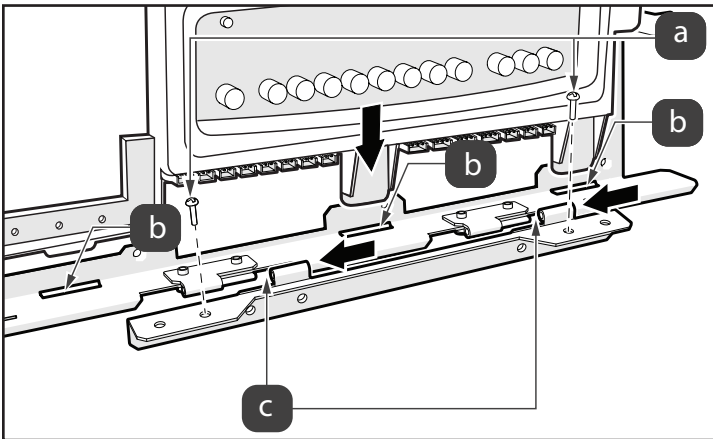

Figure 14. AquaLink® RS Conversion Kit Hinge

5. Plug in all Valve actuator's, Auxiliary, and RS-485 to the AquaLink RS Conversion Kit panel.

NOTE If a Jandy saltwater chlorinator is being installed, refer to that manual for instructions.

5.4 Connect Sensor Wires

Connect the following sensors:

- Water Temperature
- Air Temperature
- Solar Temperature (optional)

1. Reconnect the water, air, and optional solar sensors to the green terminal bar on the RS board, see Figure 15.

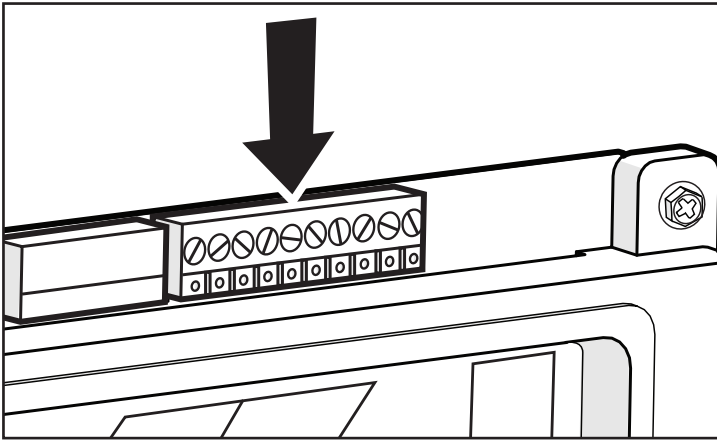

Figure 15. Connect Sensors to Green Terminal Bar

NOTE If a solar system is installed, the Freeze/Air Sensor will become the Solar Sensor. A special Freeze Sensor Kit (Part #6996) is needed. Follow instructions included with the Kit.

5.5 Connecting Heater to Low Voltage Wiring

NOTE Millivolt, electronic ignition, or heat pump with thermostatic circuitry of 24 VAC or less.

1. If connecting a Low Voltage pool heater (for example, a Jandy® brand heater), connect two (2) 14 gauge wires, designed for use in hot environments, to the proper terminals on the 10 pin terminal bar (see Figure 4). If you are connecting a High Voltage pool heater, contact Zodiac for instructions.
2. Bring the two (2) heater wires from the PCB over to the heater and wire nut in series with heater circuitry as if you were wiring a fireman's switch or a heater delay.
3. Turn the heater thermostat to the Spa position and maximum setting.
4. Turn the heater toggle switch on.
5. Do not disconnect the high limit or pressure switches.

NOTE For Spa Heater, make connection to the Spa heater Interface Board and plug it into the Spa Heater socket.

5.6 Connecting Auxiliary Equipment to PCB

Connect the high voltage relay plugs into their appropriate sockets according to the wiring diagram located on the inside of the Power Center door.

NOTE This appliance has up to 9 supply connections.

NOTE Pool filter pump socket is on the far left of the PCB and the spa filter pump relay socket is on the right after AUX 6 socket.

5.7 Finalize Hardware Installation

1. Install retaining screw on top left of AquaLink RS Conversion Kit chassis, see Figure 16(a).

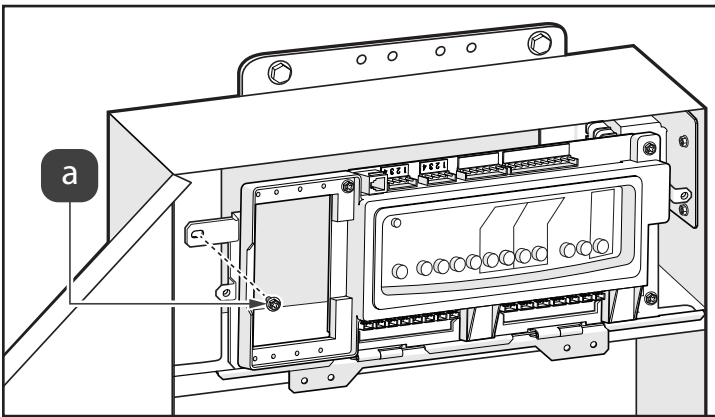

Figure 16 AquaLink RS Conversion Kit Mounting

2. Secure AquaLink RS Conversion Kit cover with 2 screws, see Figure 17(a).
3. Align tabs on bottom of low voltage dead front to the slots in the power center enclosure.
4. Secure the cover panel to the power center using the screws removed in section 2.4, see Figure 17(b).

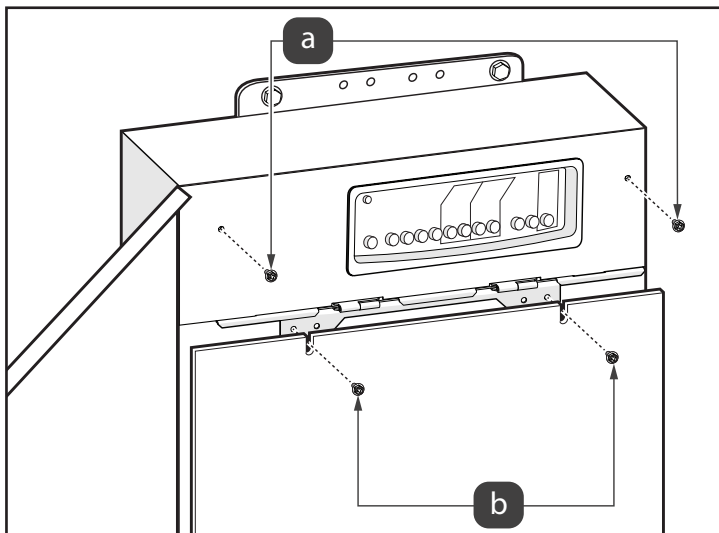

Figure 17. AquaLink® RS Conversion Kit Cover

5.8 Test the Equipment

Testing of the equipment is recommended before the automation system is put into service.

1. Use the multimeter to check continuity to ground for all metal parts.
2. Put the system into Service mode.
3. While in Service mode each auxiliary can be toggled to ensure that the equipment is functioning and that it is connected to the correctly labeled AUX on the PIB.
4. Ensure all enclosure openings are closed and sealed for water ingress protection.

Section 6. Program DIP Switch Settings

Two sets of DIP switches (S1 and S2) exist to control system configuration. The DIP switches are monitored constantly by the system and if they are changed it is immediately recognized. Restarting the system is recommended to ensure all of the settings get updated.

NOTE The DIP switches are monitored constantly, if they are changed the system knows immediately. However, you can reset the system to make sure that all of the screens get updated.

6.1 DIP Switch Functions

S1 DIP #1 ON - AUX 1 Controls Pool Cleaner

If a booster pump is installed for a pool cleaner, the relay coil for the booster pump must be plugged into the AUX 1 relay socket. If a non-booster pump cleaner is installed, plug the JVA into the cleaner JVA socket. Turn ON DIP Switch #1.

- Main filter pump turns on whenever cleaner turns on.
- Cleaner will not turn on until filter pump has been on for three (3) minutes (to ensure priming of system).
- Cleaner turns off when water circulation is to spa.
- Cleaner turns off when spa spillover feature is activated.
- Cleaner turns off for three (3) minutes when solar is activated (to ensure air is purged from the system).
- AquaLink® RS Control Panel display reads “CLEANER” rather than “AUX 1”.

S1 DIP #2 ON - AUX 2 Controls Low Speed of Spa Pump

Turn this switch ON if you want to control both speeds of a two-speed spa pump. With this switch on, the spa pump button on the AquaLink RS Control Panel will control high speed and the AUX 2 button will control low speed.

IMPORTANT You must also install a Jandy® Two-Speed Relay.

S1 DIP #3 ON - Not Used

S1 DIP #4 ON - Heater Cool Down Disabled

Turn this switch ON to disable the heater cool down safety feature on the AquaLink RS.

⚠ CAUTION

Turn this DIP Switch ON only if you are using an electric heater or a heat pump that does not retain residual heat. If you are turning this switch ON for service purposes, be sure to turn it back off.

S1 DIP #5 ON - Factory Use Only

This switch is used for calibration by Zodiac® certified technicians only. Please leave this switch in the OFF position.

S1 DIP #6 ON

When OFF a separate heater is used for the pool and spa. When ON the pool and spa share the same heater.

S1 DIP #7 ON

Change air sensor to solar sensor - Air temperature no longer displayed. Adjustable Freeze Kit must be added for freeze protection.

S1 DIP #8 ON - Heat Pump Instead of Gas Heater

Turn this switch ON if you have installed a heat pump instead of a gas heater. After thermostat setting has been reached, heater will remain OFF for 5 minutes.

S2 DIP #1 ON - Heat Pump Priority

This switch is used for configuring solar priority or heat pump priority. Set this switch to ON if Heat Pump Priority will be used. Set this switch to OFF if Solar Priority is to be used.

AquaLink RS Conversion Kit available accessories	
All Button Indoor Controller	
OneTouch Indoor Controller	
Wireless Remote (AQWHR18 dedicated water resistant)	
4 Button Spa-Side (7443, 8050, 7444)	
10 Button Spa-Side (7227, 7887, 7888, 7940)	

6.2 DIP Switch Settings

S1 DIP Switch #	OFF	ON
1	AUX1= any equipment	AUX1= Pool Cleaner
2	AUX2= any equipment	AUX2= Low Speed for a two-speed filter pump. Filter pump circuit becomes High Speed.
3	NOT USED	NOT USED
4	Heater cool down operates.	Heater cool down disabled.
5	Normal operation	Factory adjustment-when this switch is on, temperature delays are eliminated and solar temperature is displayed. Do not leave this switch in the ON position.
6	Separate Pool and Spa heater.	Sharing one (1) heater for pool and spa.

S1 DIP Switch #	OFF	ON
7	No solar system installed. Air temperature is displayed.	Changes air sensor to solar sensor. Air temperature no longer displayed. Adjustable Freeze Kit must be added for freeze protection.
8	After thermostat setting has been reached, heater will remain OFF for three (3) minutes.	Heat Pump installed; after thermostat setting has been reached, heater will remain OFF for five (5) minutes.

S2 DIP Switch #	OFF	ON
1	The AquaLink® RS will be able to control a Solar Heating system (If a solar sensor is connected to the solar sensor input)	The AquaLink RS will be able to control a Heat Pump. (The AquaLink RS will not be able to control a Solar Heating system.)

6.3 DIP Switch Settings for Solar/Heat Pump

This table shows how to configure the system for SOLAR PRIORITY or HEAT PUMP PRIORITY.

DIP S2-1	GREEN 10-PIN TERMINAL BAR	RS485 HEAT PUMP	DESCRIPTION
OFF	No sensor installed	Not connected	In this configuration there is no Solar Heating and no Heat Pump. Extra AUX is available.
OFF	Sensor installed	Not connected	In this configuration there is Solar Heating and there is Solar Priority. There is no Heat Pump.

DIP S2-1	GREEN 10-PIN TERMINAL BAR	RS485 HEAT PUMP	DESCRIPTION
OFF	Sensor installed	Connected	In this configuration there is Solar Heating and there is Solar Priority. There is Heat Pump. There is Heat Pump Priority.
OFF	No sensor installed	Not connected	In this configuration there is no Solar Heating. There is a mechanically connected Heat Pump. There is Heat Pump Priority (a limited implementation).
OFF	Sensor installed	Not connected	In this configuration there is no Solar Heating. There is a mechanically connected Heat Pump. There is Heat Pump Priority (full implementation).
OFF	Sensor installed	Connected	In this configuration there is no Solar Heating. There is an RS485 controlled Heat Pump. There is Heat Pump Priority.

Section 7. Install and Program the iQ20

The last step in the installation process is to add the iQ20 Web Connection unit which is included in this kit. Refer to the iQ20 installation guide for connection and programming information..

NOTES

NOTES

Zodiac Pool Systems LLC

2882 Whiptail Loop # 100, Carlsbad, CA 92010
1.800.822.7933 | Jandy.com

Zodiac Pool Systems Canada, Inc.

3365 Mainway, Unit 2
Burlington, ON L7M 1A6
1.888.647.4004 | ZodiacPoolSystems.ca

ETL CLASSIFIED



Intertek

Classified to:
UL STD 1563
CSA C22.2 No. 218.1

©2020 Zodiac Pool Systems LLC. All rights reserved. ZODIAC® is a registered trademark of Zodiac International, S.A.S.U., used under license. All other trademarks are the property of their respective owners. H0669200_REV F